

STANDARD MAINTENANCE AND TROUBLESHOOTING

Replacing the Cartridge

1. Shut off the water supply to the faucet
2. Turn on the faucet briefly to relieve any pressure inside the faucet
3. Move the faucet handle to the "OFF" position
4. Remove the set screw in the bottom of the lever handle 4 using the allen key
5. Pull the lever handle 4 from the faucet body
6. Unscrew the cap 5 from the lock nut 6
7. Unscrew the lock nut 6
8. Lift ceramic disk cartridge 7 from the body and replace it with a new one. Ensure the two lugs on bottom of the cartridge sit properly in the allocated holes at the base of the body
9. Re-assemble faucet in reverse order
10. Test for leakage

General Maintenance

- Clean aerator periodically for any buildup
- Do not use harsh detergents, solvents, chemical agents, especially any containing CHLORINE, or metallic sponges as these can damage the surface finish
- Clean only with soft sponge and soapy water

Spare/Replacement List

1. F205518 Rubber Washer
2. F4409 Spray Head Assembly
- 2.1. F4410 Aerator
3. F3306 Aerator Key
4. F4411 Handle Assembly
5. F4412 Cartridge Cap
6. F4413 Lock Nut
7. F4414 Cartridge
8. F3415 Fastening Set

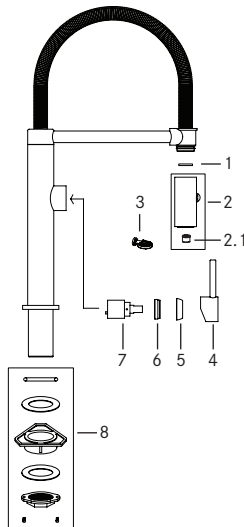

LIMITED LIFETIME WARRANTY

Franke Kitchen Systems, LLC (Franke) extends the following warranty to the original purchaser of its faucets effective January 1, 2003.

All faucets installed in a private residence will carry a limited lifetime warranty on all mechanical parts to be free of manufacturing defects in material and workmanship under normal usage. All chrome finishes carry a limited lifetime warranty; all other finishes are warranted for five (5) years from the original date of purchase.

Marine and Outdoor Installation: Franke faucets are NOT warranted for Marine and Outdoor installations.

This warranty applies only to the original owner, providing the product has been installed in accordance with our installation instructions, used as recommended and in a normal residential application. In the event of a warranty claim, the owner will be required to provide proof of purchase - save sales receipt. This warranty covers all components which make the product operational. Franke, at its option, may repair or replace the product or components necessary to restore the product to good working condition. Franke reserves the right to inspect the installation prior to the actual replacement of the product or component part. This warranty does not cover misuse or abuse, accidental damages, scuffs or scratches, improper installation, abnormal usage, negligence or damage caused by improper maintenance or cleaning. Normal wear of parts is excluded from the warranty. Damage caused by impurities or acts beyond our control are not covered. Any product or part which has been repaired or altered in any manner outside of Franke's factory, unless previously authorized in writing by Franke, will void warranty. **Any replacement excludes transportation and any labor re-installation costs.** This warranty does not allow recovery of incidental or consequential damages such as loss of use, delay, property damage or other consequential damage, and Franke accepts no liability for such damages.

The Franke warranty is limited to the above conditions and to the warranty period specified herein and is exclusive. Franke DISCLAIMS all other warranties, expressed or implied, including IMPLIED WARRANTIES OF MERCHANTABILITY AND/OR FITNESS FOR A PARTICULAR PURPOSE. This warranty gives you specific legal rights that may vary from state to state.

Further information

For any further information about our products, about the installation of them or about the guarantee, please contact the customer service department at:

Franke Kitchen Systems, LLC
Kitchen Systems Division
800 Aviation Parkway
Smyrna, TN 37167
Phone: 1-800-626-5771
Fax: 1-888-685-0007
www.franke.us/ks.com

INSTALLATION MANUAL

PESCARA

FFPD4450



MAKE IT WONDERFUL



TECHNICAL DATA

- Flow rate - 1.75 gpm at 60 psi
- Recommended water pressure - 30-85 psi
- Max water pressure - 115 psi
- Max water temperature - 158° F
- Hole size for faucet - 1 3/8"

 Certifies this faucet complies with ASME A112.18.1 / CSA
 B125.1 & NSF 61, NSF 372 and AB1953

Note

Contact us immediately if you see inconsistencies:

- Phone: 1-800-626-5771
- Email: ks-customerservice.us@franke.com
- Website: www.franke.us/ks.com

Contents in Box

1. Faucet assembly
2. Base o-ring
3. Rubber washer
4. Plastic flange
5. Fixing plate
6. Fixing nut
7. Flexible supply hoses
8. Key for aerator
9. Allen keys

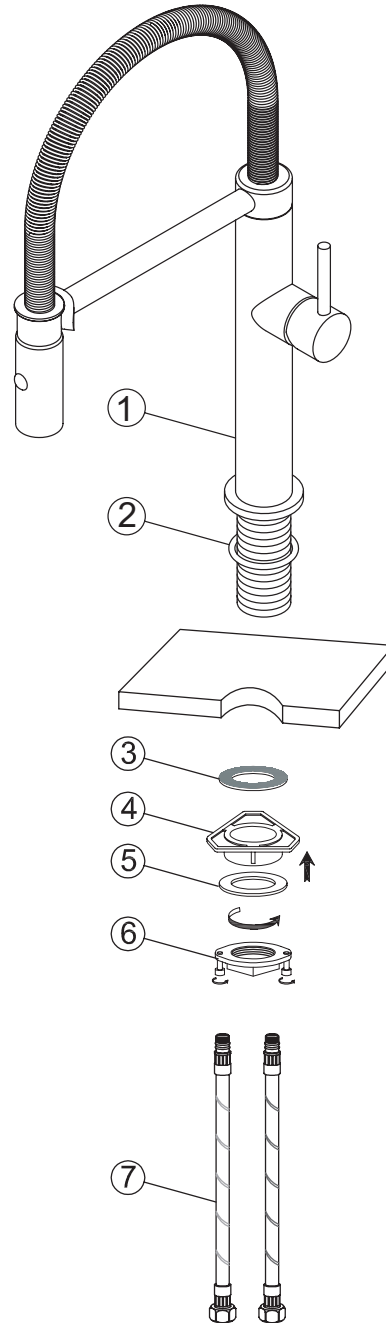
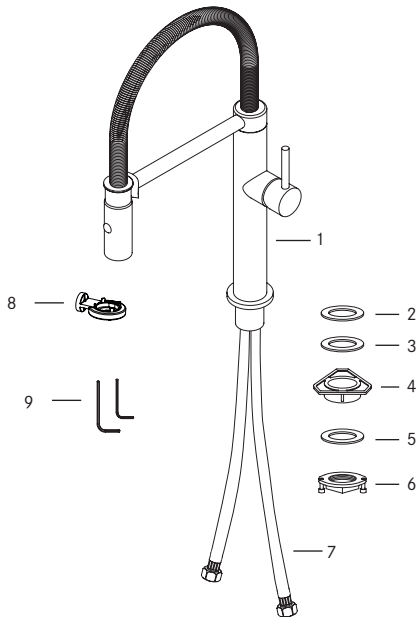

INSTALLATION INSTRUCTIONS

1. Remove all contents from the package and check for completeness.
2. Turn off water supply.
3. Cut mounting hole 1-3/8" in diameter (35mm) in the desired position (if one isn't available).

4. Place the rubber washer (2) over the mounting shank.
ATTENTION: The washer should be sitting between the countertop and faucet base.
DO NOT use putty or other sealant at this location.

NOTES:

Solid surface installation: The countertop mounting surface needs to be flat and free of debris otherwise the faucet may not sit properly. For tile installations, avoid installing faucet near or on top of grout lines. This may cause a weak joint between the faucet and the counter and could cause leaks.

5. Install the mounting hardware to the base of the faucet body in the following order - rubber washer (3); plastic flange (4) and the fixing plate (5) as illustrated.
6. Secure the faucet by tightening the Fixing Nut (6) onto the mounting shank of the faucet the body (1). Tighten screws in the fixing nut (6) to secure faucet.
7. Connect the flexible supply hoses (7) to the water supply in the house.
8. Remove the aerator using the aerator key, turn on water, flush the faucet for any debris and check for leaks. Reinstall the aerator and ensure everything is functioning properly.

