

INSTALLATION GUIDE

Little Butler® Hot Water Dispensing Faucets and Drinking Water Dispensing Faucets

LB15100 Series



LB16100 Series



DW15000 Series



DW16000 Series



LB15200 Series



LB16200 Series



TECHNICAL DATA

Pressure Range - **MINIMUM 35 PSI** - Recommended Maximum 75 PSI
Flow Rate - 1.75 GPM [6.6LPM]



ICC ES PMG has certified that this faucet complies with NSF61 and NSF372 drinking water system component requirements. These requirements meet California Health and Safety Code requirements for low lead (AB1953) as well as the low lead requirements of the US Safe Drinking Water Act of 2014.

INSTALLATION INSTRUCTIONS

- 1 Remove all contents from the package and check for completeness.

**NOTE: Call immediately if you see inconsistencies.
(1-800-626-5771) or visit
www.franke.us/ks.com**

Installation Tools:



[10mm, 12mm, 13mm, 15mm & 16mm]
Mounting Nut, Compression Fittings

Drinking Water Series Faucets (DW 15000 & DW 16000)

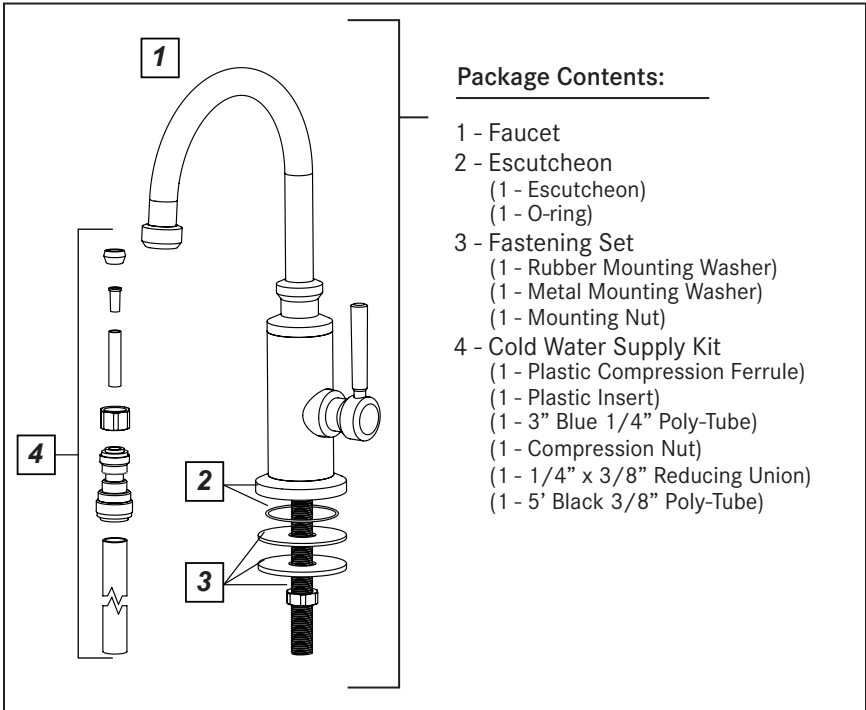

Installation

Little Butler® Series Hot only Faucets (LB15100 & LB16100)

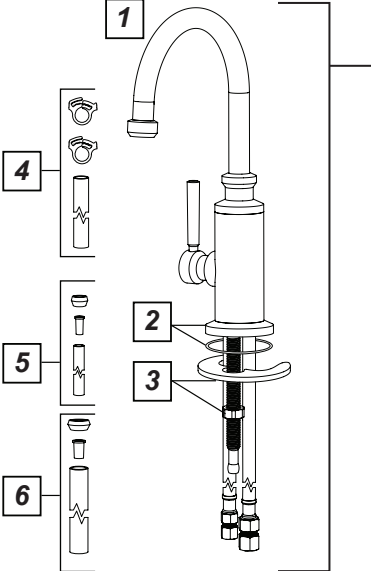

The diagram shows the faucet assembly with numbered callouts 1 through 6. Callout 1 points to the faucet handle. Callout 2 points to the escutcheon. Callout 3 points to the mounting nut. Callout 4 points to the heating tank return tubing. Callout 5 points to the heating tank supply tubing. Callout 6 points to the cold supply tubing. To the left of the main assembly, there are three vertical columns of components corresponding to callouts 4, 5, and 6. Each column shows the component and its associated hose clips or ferrules.

Package Contents:

- 1 - Faucet
- 2 - Escutcheon
(1 - Escutcheon)
(1 - O-ring)
- 3 - Fastening Set
(1 - Mounting Washer)
(1 - Mounting Nut)
- 4 - Heating Tank Return Tubing
(2 - Hose Clips)
(1 - High-Temp Silicone Tube)
- 5 - Heating Tank Supply Tubing
(1 - Plastic Compression Ferrule)
(1 - Plastic Insert)
(1 - 18" Red 1/4" Poly-Tube)
- 6 - Cold Supply Tubing
(1 - Plastic Compression Ferrule)
(1 - Plastic Insert)
(5' Black 3/8" Poly-Tube)

Little Butler® Series Hot and Cold Faucets (LB15200 & LB16200)

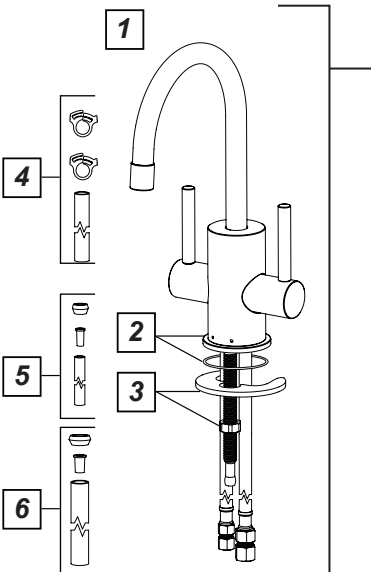

The diagram shows the faucet assembly with numbered callouts 1 through 6. Callout 1 points to the faucet handle. Callout 2 points to the escutcheon. Callout 3 points to the mounting nut. Callout 4 points to the heating tank return tubing. Callout 5 points to the heating tank supply tubing. Callout 6 points to the cold supply tubing. To the left of the main assembly, there are three vertical columns of components corresponding to callouts 4, 5, and 6. Each column shows the component and its associated hose clips or ferrules.

Package Contents:

- 1 - Faucet
- 2 - Escutcheon
(1 - Escutcheon)
(1 - O-ring)
- 3 - Fastening Set
(1 - Mounting Washer)
(1 - Mounting Nut)
- 4 - Heating Tank Return Tubing
(2 - Hose Clips)
(1 - High-Temp Silicone Tube)
- 5 - Heating Tank Supply Tubing
(1 - Plastic Compression Ferrule)
(1 - Plastic Insert)
(1 - 18" Red 1/4" Poly-Tube)
- 6 - Cold Supply Tubing
(1 - Plastic Compression Ferrule)
(1 - Plastic Insert)
(5' Black 3/8" Poly-Tube)

Installation

2

For best results, Franke recommends this faucet be installed by a licensed, professional plumber. The installer should familiarize themselves with how this dispensing faucet will be installed and function as part of a point-of-use water dispensing arrangement BEFORE the products are installed because there are several installation options. Make certain to observe all local plumbing and building codes during the installation.

First identify which dispenser and configuration you are using

Hot Water Installation Options:

The **LB1_100 Series** dispensers offer hot water only. These dispensers are required to be used in conjunction with a Franke heating tank unit. Use of a Franke filtration system in addition to the heating tank is optional, but strongly recommended in order to prolong the life and improve the performance of the heating tank, as well as providing much higher quality water as compared to un-filtered water entering the tank.

The **LB1_200 Series** dispensers offer hot and filtered water separately. These dispensers must be used in conjunction with both a Franke heating tank unit and a Franke filtration system.

These models both utilize 3 tubes to connect to the system.

- The combination stainless hose and black poly-tubing for the cold water supply into the dispensing faucet
- The combination stainless hose and red poly-tubing to carry the filtered water from the dispensing faucet to the heating tank unit.
- 1 opaque high temperature silicone tube to carry the heated water from the heating tank back to the dispensing faucet.

Cold Water Installation Options:

The **DW1_000 Series** dispensers provide filtered drinking water as well as the option of chilled drinking water. These dispensers are required to be used in conjunction with a Franke filtration system. For chilled drinking water, a Franke chiller tank unit is required. These models utilize a combination of black and blue poly-tubing to create one water supply connection to the faucet.

IMPORTANT: Franke strongly recommends using only genuine Franke components in tandem with all Franke dispensing faucets. The function of the dispensing faucets cannot be guaranteed if using filtration products, heating tanks or other accessories other than genuine Franke components. These dispensing faucets are NOT compatible with a REVERSE OSMOSIS (RO) FILTRATION SYSTEM and using them with a RO system WILL VOID THE PRODUCT WARRANTY.

Installation

3

It is recommended to take the components and locate their optimum positions before starting the installation. Make sure there is adequate clearance for the dispenser handle(s) to open fully without interference. Make sure all plumbing and electrical connections will reach the intended mounting positions for all the components and there will be no obstructions or sharp bends in plumbing. Make sure the counter top is no thicker than 2-1/4".

WARNING: Before inserting poly-tubing into the push fittings in subsequent steps, ensure the ends of the tubing used are cut square and free of burrs, both inside and outside. Ensure there are no gouges, scratches, or any other form of damage within 1" from the cut end of the tubing. Damage in this area can cause leakage. Do NOT use any thread sealant, plumbers putty, glue, or other adhesive chemicals on the tubing or push fittings. This can damage the o-rings inside the push fittings and cause leakage. Any foreign substances used on the push fitting connections will VOID THE PRODUCT WARRANTY. Do not use tools or modify any of the push fit connections as this could damage the connection, resulting in leaks and will VOID THE PRODUCT WARRANTY.

NOTE: When installing poly-tubing into push fit connections, the tubing should be firmly pressed into the fitting until it stops to ensure a proper seal. If you should need to remove the tubing from the push fitting, use your thumb and forefinger to press and hold in on the collar while gently pulling the tube out.

4

Ensure proper hole is in place for the faucet. This faucet is designed for a 1-1/4" (32mm) mounting hole.

5

- Steps 5-8 pertain to connection of the DW1_000 Series faucets. If you are installing an LB1_100 or LB1_200, skip to Step 9.

- Remove the Mounting Nut and 1/4" compression nut from the mounting nipple.

- Install the escutcheon to the base of the faucet by sliding it over the mounting nipple. Make sure the o-ring is positioned in its seat in the escutcheon.

- Place the faucet in the hole, orienting the spout towards the sink bowl with the handle in position to rotate forward.

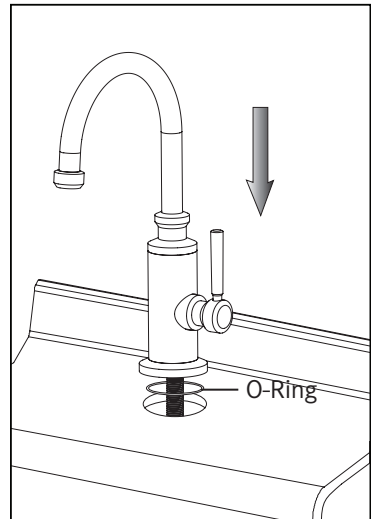
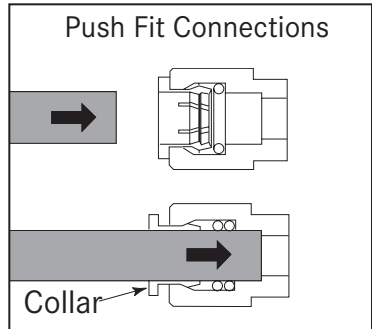

Installation

- 6 Install fastening set as shown: Rubber Washer, Metal Mounting Washer, Mounting Nut.

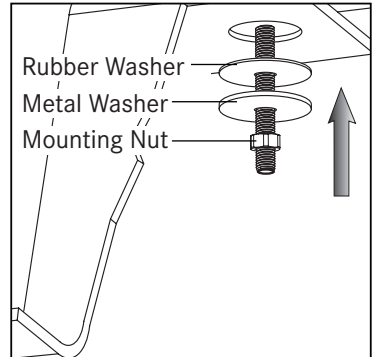

- 7 Connect the cold water supply to the faucet:

- Slide the plastic ferrule and the compression nut onto the blue 1/4" poly-tubing and place the plastic insert in the end of the tubing as illustrated.

- Insert the assembled tubing into the mounting nipple and tighten the compression nut

- Connect the reducing union to the 1/4" blue poly-tubing and insert the 3/8" black poly-tubing.

NOTE: There should be a service label attached to the black poly-tubing. Be sure to orient the tubing so the label is visible after assembly

- DO NOT REMOVE LABEL.

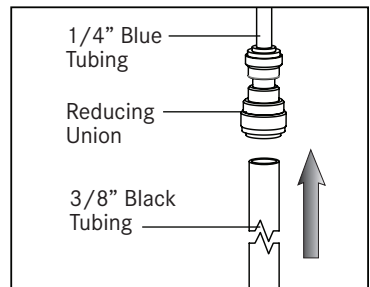
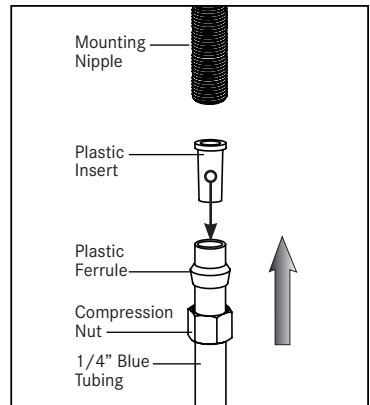

- 8 Connect the black 3/8" poly-tubing to the outlet of the filtration system as outlined in the filtration system instructions.

Installation

9

- Steps 9 - 15 pertain to connection of the LB1_100 and LB1_200 Series faucets
- Remove the 3/8" compression nut from the factory installed steel supply hose.
- Slide the plastic ferrule and the compression nut onto the black 3/8" poly-tubing and place the plastic insert in the end of the tubing as illustrated
- Connect the assembled tubing to the steel supply hose and tighten the compression nut

10

- Connect the hot water supply to the faucet:
- Remove the 1/4" compression nut from the factory installed steel supply hose.
 - Slide the plastic ferrule and the compression nut onto the red 1/4" poly-tubing and place the plastic insert in the end of the tubing as illustrated.
 - Connect the assembled tubing to the steel supply hose and tighten the compression nut

NOTE: There should be a service label attached to one of the steel supply hoses. **DO NOT REMOVE LABEL.**

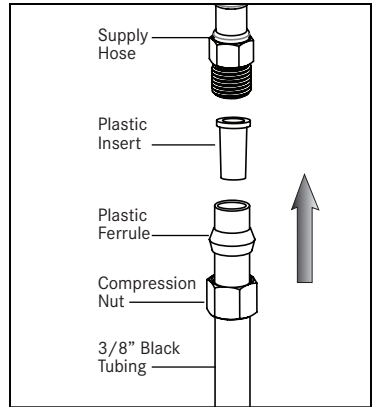

11

- Remove the fastening hardware from the mounting nipple
- Install the escutcheon to the base of the faucet by sliding it over the mounting nipple and supply hoses. Make sure the o-ring is positioned in its seat in the escutcheon.
- Place the faucet in the hole, orienting the spout towards the sink bowl with the handles in position to rotate forward.

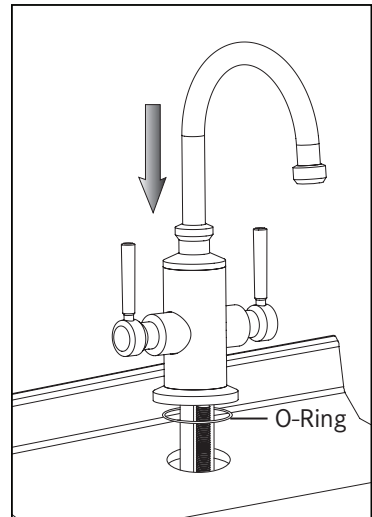

Installation

- 12** Install Mounting Washer and Mounting Nut as shown.

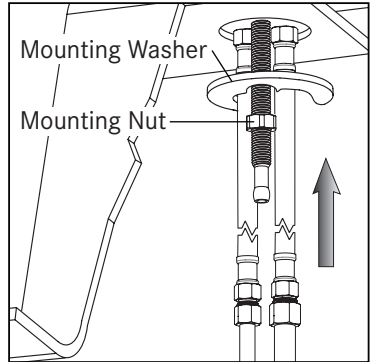

- 13** Connect the black 3/8" poly-tubing from the faucet to the filtration system. If you decide not to utilize a filtration system with your LB1_100 series faucet, you must provide a connection for the black 3/8" poly-tube to the home's cold water supply.

- 14** Connect the high temp silicone tubing to the mounting nipple and secure the tubing using the hose clip.

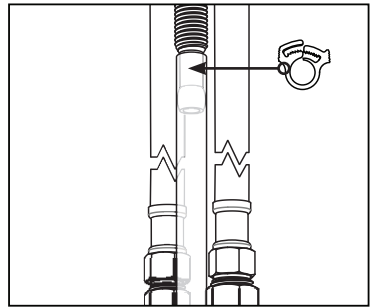

- 15** The 1/4" red poly tubing & silicone tubing provided with the faucet are intended to be longer than will be necessary to make the connections to the heating tank. It is recommended to cut these tubes to the proper length to remove any unnecessary loops or low spots in the tubing after installed. Connect the red 1/4" Heating Tank Supply Tubing to the heating tank inlet and the high temp silicone Heating Tank Return Hose to the heating tank outlet per the instructions provided with the heating tank.

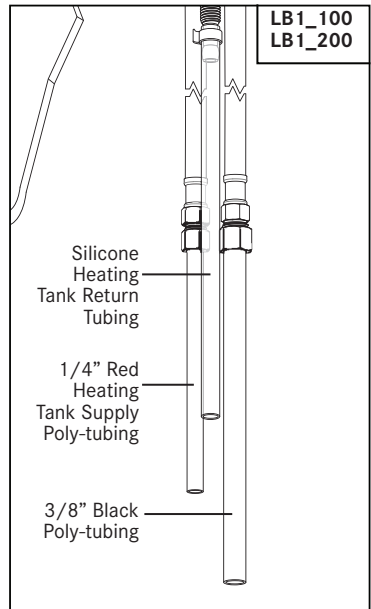

Usage

- 1 Pull the handle(s) forward to turn on the water supply. Both valves will stay in the 'on' position until rotated back to upright position.

Note: The spout has a 360° swivel capability

- 2 **WARNING!** Do not operate both handles at the same time, as this can build up pressure in the heating tank causing the bladder to expand and eventually burst. Such damage is not covered by the warranty.

- 3 **Seasonal Shutdown:**

If you plan to be away from home for extended periods of time, refer to the filtration system instructions and heating tank instructions (if applicable) under the Winterizing or Seasonal Shutdown sections to prevent system failures.

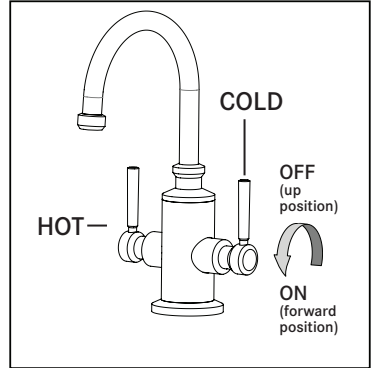

MAINTENANCE

1 Trouble Shooting

PROBLEM	POSSIBLE CAUSE	RECOMMENDED ACTION
Water spews and steams forcefully from spout with the dispenser in the off position	<ul style="list-style-type: none"> -The heating tank is boiling because temperature setting is too high -The heating tank is boiling because there may be a problem with internal heating mechanism 	<ul style="list-style-type: none"> Lower temperature adjustment on the heating tank. Turn on faucet lever and run water until stream is normal again. If spewing returns, lower temperature again until spewing stops
Water is not hot	<ul style="list-style-type: none"> -The heating tank is unplugged -The power supply to the heating tank is inoperable -There may be a problem with the internal heating mechanism on the heating tank 	<ul style="list-style-type: none"> -Make sure heating tank is connected to a properly grounded electric outlet -Make sure the circuit breaker or fuses are functioning properly
Water is dripping from spout intermittently	<ul style="list-style-type: none"> -This is normal during water heating cycles but should only occur for a few minutes. If dripping is continual it could be low water pressure to the heating tank 	<ul style="list-style-type: none"> -Check the supply valve to ensure it is fully open and there are no obstructions or kinks in the water lines. Also check for clogged water filters -Check supply hoses for loops or low sections

2 Replacement Parts

Model #	Replacement Part # for Identified Part													
	#1 Cold Cartridge	#2 Hot Cartridge	#3 Handle Assembly		#4 DW Series Mounting Kit	#5 LB Series Mounting Kit	#6 1/4" Hot Supply Hoses	#7 3/8" Cold Supply Hoses	#8 Connection Kits	#9 Silicone Tubing Kit	#10 3/8" Cold Wtr. Supply Tubing Blk.	#11 1/4" Cold Wtr. Supply Tubing Blu.	#12 1/4" Hot Wtr. Supply Tubing Red	#13 1/4" x 3/8" Reducing Union
			Cold	Hot										
LB15100 Series	-	5-022	-	5-037*	-	5-026	5-028	5-029	5-030	5-031	10305	-	10309	-
LB15200 Series	5-021	5-022	5-038*	5-038*	-	5-026	5-028	5-029	5-030	5-031	10305	-	10309	-
DW15000 Series	5-021	-	5-037*	-	5-027	-	-	-	5-035	-	10305	10308	-	10322
LB16100 Series	-	5-022	-	5-043*	-	5-026	5-028	5-029	5-030	5-031	10305	-	10309	-
LB16200 Series	5-021	5-022	5-044*	5-044*	-	5-026	5-028	5-029	5-030	5-031	10305	-	10309	-
DW16000 Series	5-021	-	5-043*	-	5-027	-	-	-	5-035	-	10305	10308	-	10322

* Must Identify Color/ Finish when ordering replacement parts.

CH = Chrome, MB=Matte Black, PN=Polished Nickel and SN=Satin Nickel
(ie. 5-037CH=Chrome, etc...)

DW1_000 Series

(Faucet pictured may differ from faucet you have. See front cover for accurate illustration.)

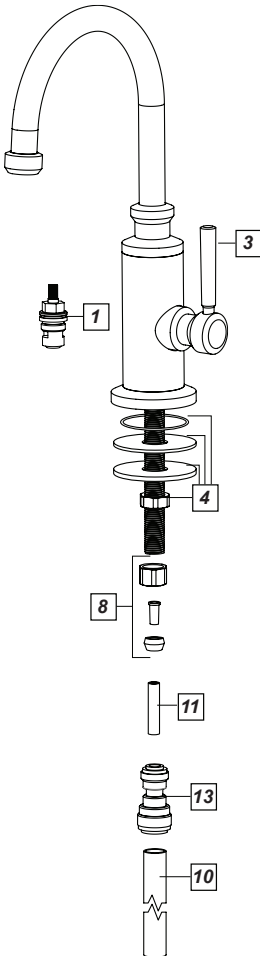

LB1_100 Series

(Faucet pictured may differ from faucet you have. See front cover for accurate illustration.)

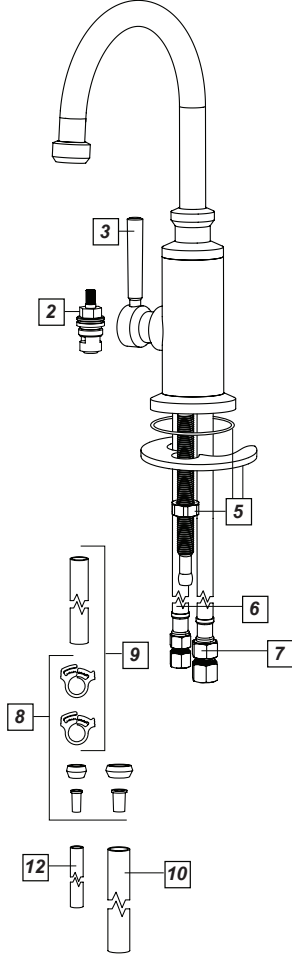

LB1_200 Series

(Faucet pictured may differ from faucet you have. See front cover for accurate illustration.)

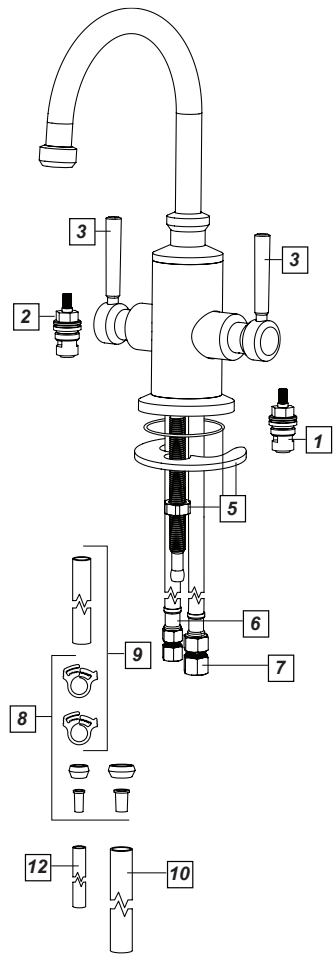

WARRANTY

Congratulations on the purchase of this Franke product! Franke is one of the world's largest manufacturers of kitchen systems. Our products are manufactured using the highest degree of technology quality and design. As a result we are proud to offer the following warranty.

Franke Kitchen Systems, LLC, warrants the quality of its water dispensing systems to be free from manufacturing defects for a period of **five** years from the date of purchase. This warranty applies only to the original owner, providing the product has been installed in accordance with these installation instructions, used as recommended and in a normal residential application. **In the event of a warranty claim, the owner will be required to provide proof of purchase – SAVE ORIGINAL SALES RECEIPT!** This warranty covers all components necessary to restore the product to good working condition. Franke reserves the right to inspect the installation prior to the replacement of the product or component part.

Marine and Outdoor Installation: Franke Kitchen Systems, LLC faucets are NOT warranted for Marine and Outdoor installations.

This warranty does not cover misuse or abuse, accidental damage, scuffs or scratches, abnormal usage, negligence or damage caused by improper maintenance or cleaning. Normal wear of parts is excluded from warranty. Damage caused by impurities or acts beyond Franke's control are not covered. Any product or part which has been repaired or altered in any manner outside of Franke's factory, unless previously authorized in writing by Franke, will void warranty. **Any replacement excludes transportation and any labor re-installation costs.** This warranty does not allow recovery of incidental or consequential damages such as loss of use, delay, property damage or other consequential damage, and Franke accepts no liability for such damages.

The Franke warranty is limited to the above condition and to the warranty period specified herein and is exclusive. Franke **DISCLAIMS** all other warranties, expressed or implied, including the **IMPLIED WARRANTIES OF MERCHANTABILITY AND/OR FITNESS FOR A PARTICULAR PURPOSE.** This warranty gives you specific legal rights which may vary from state to state.

Further Information

For any further information about our products, about the installation of them, or about the guarantee, please contact our Customer Service Department:

Franke Kitchen Systems, LLC
800 Aviation Parkway
Smyrna, TN 37167
Phone: 1-800-626-5771
Fax: 1-888-685-0007
www.franke.us/ks.com



Franke Kitchen Systems, LLC
800 Aviation Parkway
Smyrna, TN 37167
Phone: 1-800-626-5771
Fax: 1-888-685-0007
www.franke.us/ks.com