



FRANKE PROFESSIONAL SERIES GAS COOKTOP OPERATION MANUAL

**FIG301S1 N/L & FIG301B1 N/L
FIG604S1 N/L & FIG604B1 N/L
FIG903S1 N/L & FIG903B1 N/L
FIG906S1 N/L & FIG906B1 N/L
FIG905B1 N/L
FLG945B1 N/L
FLG1003B1 N/L**

5 YEAR CUSTOMER CARE WARRANTY

All FRANKE professional series appliances come with a 5 year parts and labour warranty. FRANKE will correct, free of charge, any defects in material or workmanship for the period of 5 years, subject to the terms of our warranty stated below. At FRANKE we place great importance on customer satisfaction and that is why we have established a dedicated and experienced customer support team that you can rely on.

Should you ever need to make a warranty related inquiry about your FRANKE product simply call 03 9700 9100 to speak with our friendly customer service consultants. We suggest you have the following information close at hand to make the process as easy as possible.

1. Model number of your appliance
2. Serial number of your appliance
3. A copy of your original purchase receipt
4. Address details of where the appliance is installed

This warranty will be null and void if the appliance is used for outdoor and commercial purposes. Some examples of outdoor and commercial purposes but not limited to, include restaurants, cafés, schools, clubs, alfresco areas with open walls or hoods used above barbecues.

Please note: The benefits provided by this warranty are in addition to all other rights and remedies in respect to the product which the consumer has under the Australian competition and Consumer Act 2010.

1. This warranty only applies for products installed by a qualified person and when provided with a certificate of compliance in accordance with State/Territory laws.
2. This product must be used in accordance with the manufacturer's instructions. This warranty does not apply should the defect in or failure of the product be attributable to misuse, abuse, accident or non-observation of the manufacturer's instructions on the part of the user. FRANKE appliances does not accept liability for any direct or consequential loss, damage or other expense caused by or arising out of any failure to install or use the product in accordance with the manufacturer's instructions.
3. The warranty does not cover normal wear and tear, insect or vermin infestation, cosmetic changes, excessive spillage, incorrect or incomplete installation, power surges, incorrect or improper operation, inadequate care and warranty claims.
4. FRANKE Appliances, at its own discretion may replace or repair any defective component(s) to affect a repair due to any faulty workmanship and material. The warranty does not cover breakage of outer glass panels attributed to external damage.
5. The warranty provided is a "Repair Warranty" and in an extreme event if a repair can not take place, a replacement will be provided of an equivalent current model where the balance of the warranty period from the original date of purchase will take affect.
6. This warranty is immediately void if the serial or model number label is removed, defaced, serviced or repaired by an unauthorised/unqualified person or used for industrial/commercial purposes.
7. Warranty will be only provided when a proof of the original purchase is presented to an authorised dealer or reseller before or at the time of service.
8. This warranty does not cover any corrosion or defect as a result of the product being installed in an environment in which the appliance is protected from the weather.
9. It is the responsibility of the customer to ensure the appliance is easily accessible for a service technician to carry out required repairs. Any obstruction prohibiting access to the product by building materials of any kind will be required to be removed and reinstalled by the customer.
10. This warranty covers the first 50km travelled by a repair technician to the appliance location and return. Any travel in excess of 50km each way is not covered by the warranty.

FRANKE has a service network in all metropolitan areas and most regional areas. Where the warranty claim has been made outside a radius of 50km from any store where the product can be purchased, the customer is responsible for the cost of delivery to the nearest service agent or the travel cost for a technician to travel to a location outside the 50km radius.

YOUR STATUTORY RIGHTS

FRANKE products fully assures all customers that our goods come with guarantees that cannot be excluded under the Australian Consumer Law. You are entitled to have the goods repaired or replaced if the goods fail to be of acceptable quality and the failure does not amount to a major failure. You are also entitled to a replacement or refund for a major failure and for compensation for any other reasonably foreseeable loss or damage. The benefits under FRANKE's warranty are in addition to other rights you have at law in relation to the appliances or services to which the warranty relates.

APPLIANCE OPERATION MANUAL

CONTENTS

PG

| | |
|---|-----|
| GENERAL INFORMATION | 4 |
| SAFETY WHEN IN USE | 5 |
| SAFETY | 6-7 |
| ELECTRICAL AND GAS CONNECTION | 8 |
| INSTALLATION INSTRUCTIONS | 9 |
| LEGEND AND MANUAL IGNITION FOR GAS BURNERS | 10 |
| GENERAL ASSEMBLY PROCEDURE FOR INSTALLATION | 13 |
| TO USE YOUR NEW FRANKE COOKTOP | 14 |
| BURNER TOUCH CONTROL | 15 |
| CARE AND MAINTENANCE | 16 |
| FAULT FINDING / ABNORMAL OPERATION | 17 |

MODELS COVERED

FIG301S1 N/L & FIG301B1 N/L

FIG604S1 N/L & FIG604B1 N/L

FIG903S1 N/L & FIG903B1 N/L

FIG906S1 N/L & FIG906B1 N/L

FIG905B1 N/L

FLG945B1 N/L

FLG1003B1 N/L

GENERAL INFORMATION

PLEASE KEEP AND READ FOR FUTURE REFERENCE

The Franke range of cooktops are state of the art appliances featuring the latest in flame auto safety shut-off. Should the flame on any burner be extinguished accidentally then the gas flow to that burner will automatically cease to flow, ensuring no hazardous build up of flammable gas from the cooktop can then occur.

This appliance is not intended for use by children or persons with reduced physical, sensory or mental capabilities or lack of experience and knowledge, unless they have been given supervision or instruction concerning use of the appliance by a person responsible for their safety.

The appliances feature easy to clean ceramic or stainless steel cooktops together with brass forged burners and cast iron pan supports.

They are available in Natural Gas or LP Gas configurations.

Choice of mixed energy gas and induction models offer the best in performance from simmer to high speed using FullSpectrum gas burners, or the fantastic induction heating.

Various sizes and numbers of burners in the Franke cooktop range allows you to choose the appliance or number of appliances to meet your cooking needs

NOTE: ALL MATERIAL SURROUNDING THE INSTALLATION MUST BE ABLE TO WITHSTAND TEMPERATURES OF 95 °C DURING PERIODS OF OPERATION. CERTAIN MATERIALS (VINYL WRAP) MAY SUFFER DAMAGE WHEN HEATED FROM AN APPLIANCE.

This appliance has been constructed and distributed in compliance with the essential requirements of the following EEC DIRECTIVES, EUROPEAN NORMS, Australian & New Zealand Standards.

CE Marking – 93/68 Low Voltage – 73/23 EMC – 89/336; Materials that can touch food – 89/109;
Safety Standards – EN 60 335 – 2 – 6 ASNZS3350-1, ASNZS3350-2-6

When first used an odor may be emitted by any residual protective finish or moisture, which will cease after a short period of time

FOR YOUR SAFETY

We have taken care to ensure that this appliance operates safely by way of meeting and exceeding all Australian Safety and Performance Standards applied to this type of product. You should read and understand the safety issues to avoid the possibility of an accident.

IF YOU SMELL GAS

Open windows and doors, and extinguish any open flame. Do not touch electrical switches and call your gas supplier immediately.

SAFETY WHEN IN USE

1. Remember this appliance produces heat and therefore some parts will get hot. Let pan supports and other surfaces cool down before touching them.
2. Do not leave children unattended near the appliance when it is hot or in use.
3. Do not store or use petrol or other flammable vapours or liquids in the vicinity of this or any other gas appliance.
4. Do not use or store flammable materials near this appliance.
5. Do not spray aerosols in the vicinity of this appliance while is in operation.
6. Do not modify this appliance.
7. Do not use as a space heater.
8. Do not use the burners as a room heater.
9. Do not allow clothing to pass over or near to the flame.
10. Do not leave handles of saucepans protruding out into the room or over adjacent burners. Always check that the pot is stable and will not be likely to tip its contents before you release your grip.
11. Do not store items of interest to children in the cabinets above the appliance. Children climbing or standing on the appliance could result in serious injury.
12. Do not position pans off-centre to the burner. Adjust the flame to remain under the pan.

GAS CONTROLS - LIGHTING PROCEDURE

NOTE: ALWAYS ENSURE ALL PARTS ARE CLEAN AND DRY PRIOR TO OPERATING ANY BURNER.

It is important that the burner assembly sequence on the previous page is performed prior to initial operation of the cook top or light back may occur which could affect the burner.

WHEN INSTALLED IN A CARAVAN OR MARINE CRAFT DO NOT USE THIS APPLIANCE AS A SPACE HEATER. DO NOT PLACE COMBUSTIBLE MATERIAL OR PRODUCTS ON THIS APPLIANCE AT ANY TIME. DO NOT USE AEROSOLS NEAR THIS APPLIANCE WHILST IT IS IN OPERATION.

SAFETY

PRECAUTIONS BEFORE USING

- Unpack all the materials.
- The installation and connection of the appliance must be done by approved and qualified specialists. The manufacturer cannot be responsible for damage caused by installation or connection errors.
- When used, the appliance must be correctly installed in a kitchen unit and an adapted and approved work surface.
- This domestic appliance is exclusively for the cooking of food, to the exclusion of any other domestic, commercial or industrial use.
- Remove all labels and self-adhesives from the ceramic glass.
- Do not change or alter the appliance.
- The cooking plate cannot be used as freestanding unit or as a working surface.
- The appliance must be grounded and connected in compliance with local standards.
- Do not use any extension cable to connect the cooktop.
- The appliance cannot be used above a dishwasher or a tumble dryer: steam may damage the electronic appliances.
- The appliance is not intended to be operated by means of external timer or separate remote control system.
- This appliance is not suitable for use with aftermarket lids or covers.

USING THE APPLIANCE

- Switch the heating zones off after use.
- Keep an eye on the cooktop when cooking with grease or oils as they may quickly ignite.
- Be careful not to burn yourself during or after using the appliance.
- Make sure no cable of any fixed or moving appliance makes contact with the glass or the hot saucepan.
- Magnetic objects (credit cards, floppy disks, calculators) should not be placed near the appliance when in use.
- Metallic objects such as knives, forks, spoons and lids should not be placed on the cooktop surface as they can get hot.
- In general, do not place any metallic object except heating containers on the glass surface. In case of untimely activation or residual heat, they may heat, melt or even burn.
- Never cover the appliance with a cloth or a protection sheet. This may become very hot and catch fire.
- This appliance is not intended for use by persons (including children) with reduced physical, sensory or mental capabilities, or lack of experience and knowledge, unless they have been given supervision or instruction concerning use of the appliance by a person responsible for their safety.
- Children should be supervised to ensure that they do not play with the appliance.
- This appliance is not intended to be operated by means of an external timer or separate remote-control system.

SAFETY

PRECAUTIONS NOT TO DAMAGE THE APPLIANCE

- Raw pan bottoms or damaged saucepans (not enameled cast iron pots) may damage ceramic glass.
- Sand or other abrasive materials may damage ceramic glass.
- Avoid dropping objects, even little ones, on the vitroceramic.
- Do not hit the edges of the glass with saucepans.
- Make sure that the ventilation of the appliance is in accordance with the manufacturer's instructions.
- Do not put or leave empty saucepans on the vitroceramic cooktops.
- Sugar, synthetic materials or aluminum sheets must not come into contact with the heating zones. These may break or damage the vitroceramic glass when cooling: switch on the appliance and take them immediately out of the hot heating zone (be careful not to burn yourself).
- **WARNING:** Danger of fire: do not store items on the cooking surface.
- Never place any hot container over the control panel.
- If a drawer is situated under the installed appliance, make sure the space between the contents of the drawer and the base of the appliance is large: at least (2 cm). This is essential to guarantee correct ventilation.
- Never put flammable objects (ex. sprays) into the drawer under the vitroceramic cooktop. Cutlery drawers must be resistant to heat.

PRECAUTIONS IN CASE OF APPLIANCE FAILURE

- If a defect is noticed, switch off the appliance and turn off the electrical supply.
- If the ceramic glass is cracked or fissured, you must unplug the appliance and contact after sales service.
- Servicing must be done by specialists. Do not open the appliance by yourself.
- **WARNING:** If the surface is cracked, switch off the appliance to avoid the possibility of electric shock.
- If the supply cord is damaged, it must be replaced by the manufacturer or its service agent or similarly qualified person in order to avoid a hazard.

OTHER PROTECTIONS

- Ensure that the pot or pan is always centred on the cooking zone. The bottom of the pan must cover as much of the cooking zone as possible.
- For the users of pacemaker, the magnetic field could influence its operating. We recommend discussing this with the retailer or a doctor.
- Do not to use aluminum or synthetic material containers: they could melt on cooking zones that are still hot.
- **NEVER** try to extinguish a fire with water, but switch off the appliance and then cover flame e.g. with a lid or a fire blanket.

ELECTRICAL CONNECTION

- The installation of this appliance and the connection to the electrical network should be entrusted only to an electrician following the normal regulations.
- Protection against the parts under tension must be ensured after the building-in.
- The information on connections necessary are on the stickers. Place them on the cooktop casing near the connection box.
- Connection to the mains must be made using an earthed plug, which must be accessible after installation, or via an omnipolar circuit breaking device with a contact opening of at least 3 mm.
- The electrical circuit must be separated from the network by adapted devices, for example: circuit breakers, fuses or contactors.
- If the appliance is not fitted with an accessible plug, a disconnecting means must be incorporated in the fixed installation, in accordance with the installation regulations.
- The inlet hose must be positioned so that it does not touch any of the hot parts of the cooktop or oven.

This appliance must only be connected to a 230V ~ 50/60Hz. Network.

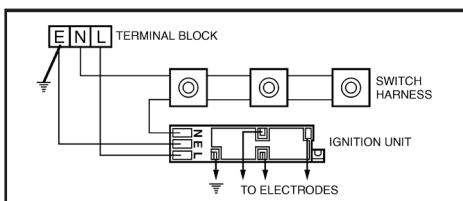

FIG903B1N/L, FIG903S1N/L, FLG1003B1N

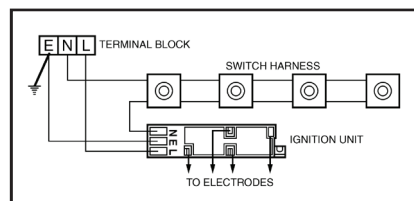

FIG604S1N/L, FIG604B1N/L

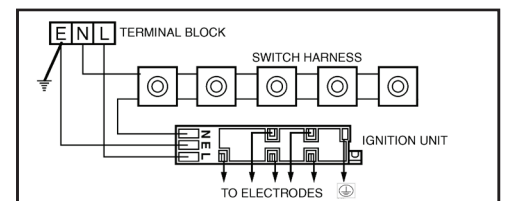

FIG905B1N/L, FLG945B1N/L

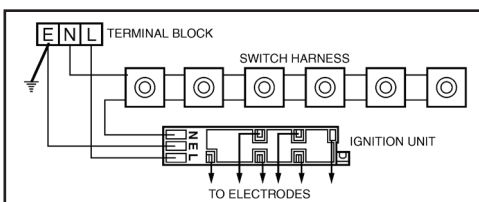

FIG906S1N/L, FIG906B1N/L

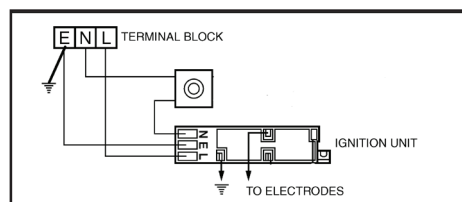

FIG301S1N/L, FIG301B1N/L

GAS CONNECTION

An appliance suitable for gas connection must only be installed by an authorised person.

The installation must comply with these instructions, any local regulations and the requirements of AS/NZS 5601.

GENERAL INFORMATION

- The gas connection is 1/2 in copper compression mounted horizontally facing the rear of the appliance, the connection point is 300mm from the left-hand side of the cut out and 100mm back from the front edge of cut out.
- Where fitted the regulator must be located so that it is accessible after installation.
- This appliance is not intended for use by children or persons with reduced physical, sensory or mental capabilities or lack of experience and knowledge, unless they have been given supervision or instruction concerning use of the appliance by a person responsible for their safety.
- IF YOU SMELL GAS - Open windows and doors and extinguish any open flame. Do not touch electrical switches and call your gas supplier immediately.

SAFETY WHEN IN USE

- Remember this appliance produces heat and therefore will get hot. Let pan supports and other surfaces cool down before touching them.
- Do not leave children unattended near the appliance when it is hot or in use.
- Do not store or use petrol or other flammable vapours or liquids in the vicinity of this or any other gas appliance.

INSTALLATION INSTRUCTIONS

The installation comes under the exclusive responsibility of service. The installer must respect the legislation and the standards enforce in his home country.

How to stick the gasket

The gasket supplied with the cooktop avoids all infiltration of liquids in the cabinet. Installation has to be done carefully, in conformity of the following drawing.

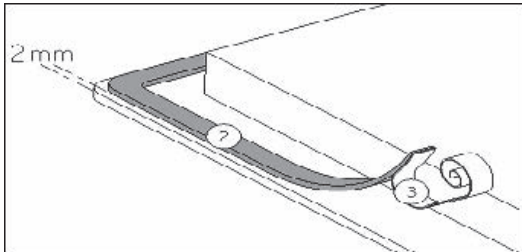

Stick the gasket (2) two millimeters from the external edge of the glass, after removing the protection sheet (3).

- The bench top or the support in which the cooktop is to be fitted, as well as the edges of the furniture, the laminates coatings and the glue used to fix them, must be able to resist temperatures of up to 100°C.
- Do not install the cooktop to the top of a non ventilated oven or dishwasher.
- The underside of the cooktop requires a clearance of 20mm from the under side of the induction unit to ensure good air circulation of the electronic device.
- If a drawer is placed under the unit, do not put flammable objects (for examples sprays) or non heat resistant objects inside.
- Any adjoining wall surface situated within 200mm from the edge of any hob burner must be a suitable non-combustible material for a height of 150mm for the entire length of the hob.
- The over head clearance should be 750mm unless the over head surface is non combustible or the range hood is rated for lower clearance taking into account the installation requirements of AS/NZS 5601 where applicable.
- Where the appliance is supplied to be plugged into a GPO the plug must not be removed.
- Where the appliance is supplied with two power leads the GPO's must be rated to suit the plug or greater.

CUT OUT SIZES

FLG1003B1 N/L

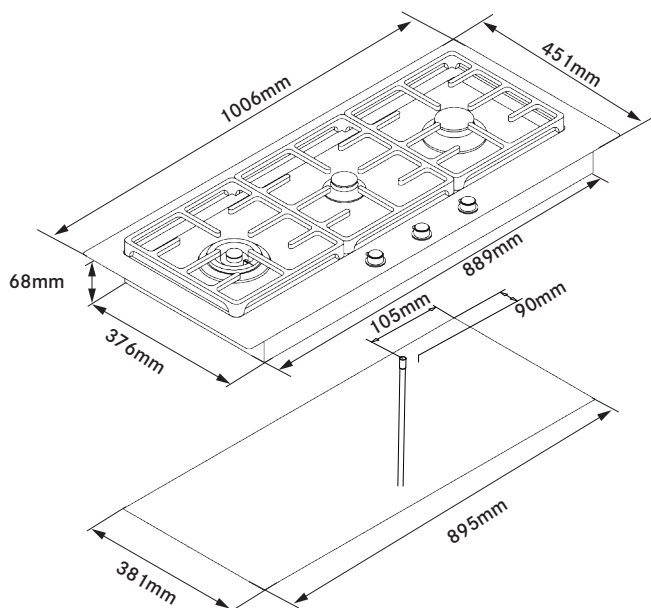

FLG945B1 N/L

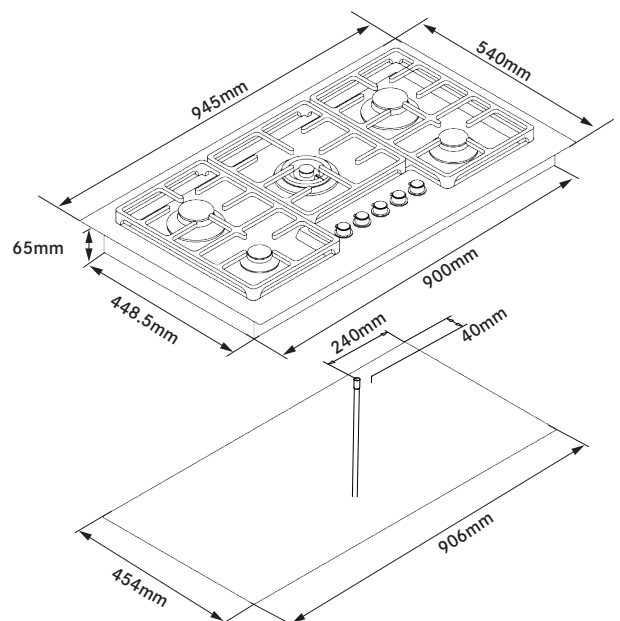

INSTALLATION INSTRUCTIONS

FIG301

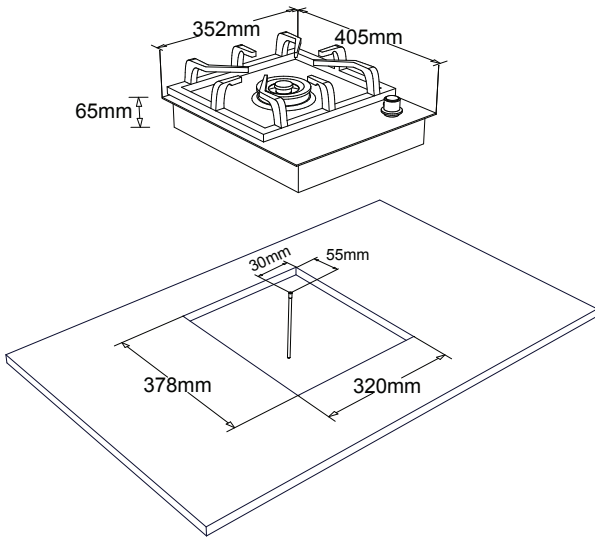

FIG604

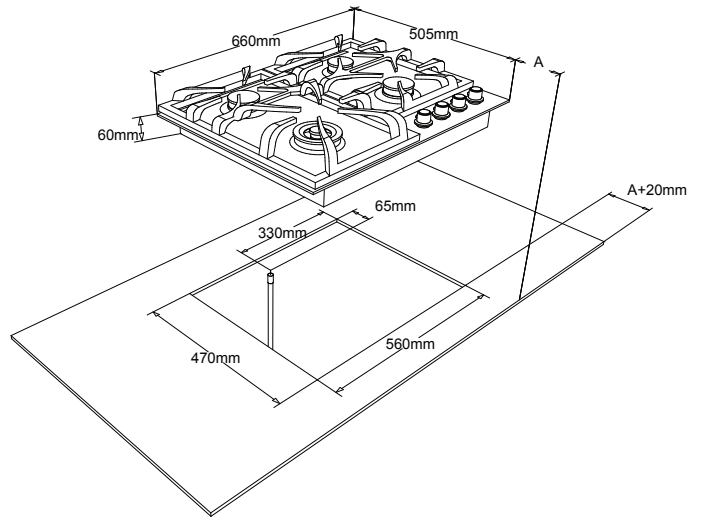

FIG903

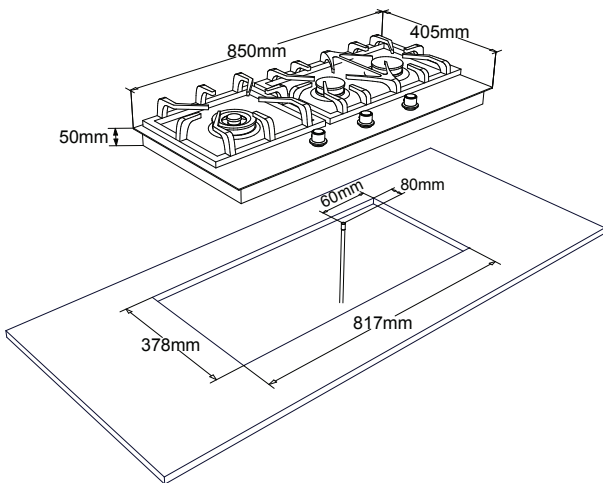

FIG905

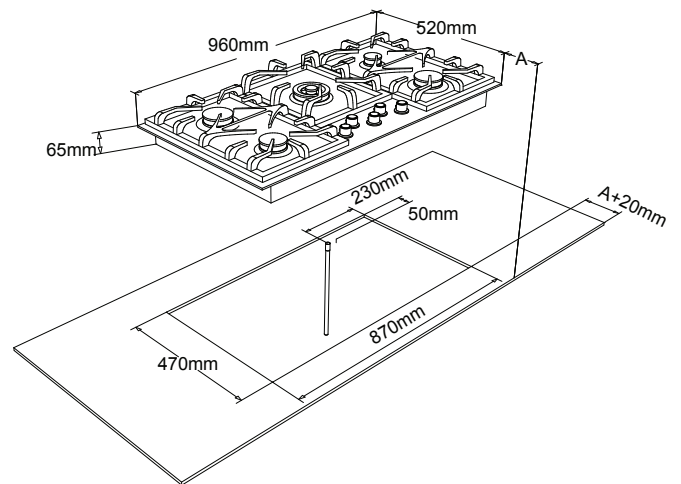
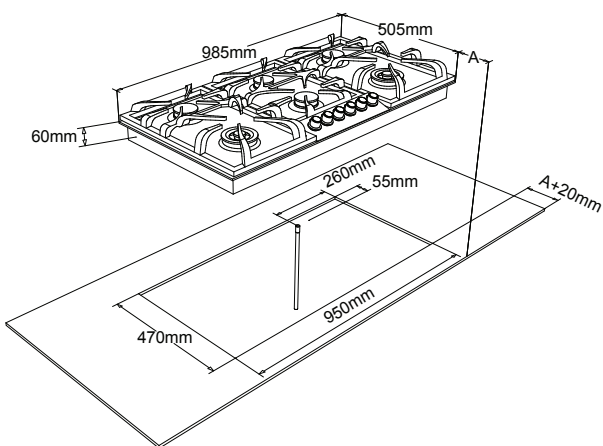

FIG906



The distance from the top of the benchtop to the top of the wok trivet is 65mm and the distance from the top of the benchtop to the top of the A,B and C burners are 45mm

Respective locations of gas inlet and power supply

INSTALLATION INSTRUCTIONS

NOTE: CONNECTION OF THE APPLIANCE TO THE GAS SUPPLY MUST BE IN ACCORDANCE WITH THE REQUIREMENTS OF AS/NZS 5601. A ½ INCH BSP CONNECTION AT THE INLET IS RECOMMENDED AND THE GAS SUPPLY LINE TO THE APPLIANCE MUST BE OF ADEQUATE LENGTH TO ALLOW SUFFICIENT WITHDRAWAL OF APPLIANCE FOR SERVICE OR DISCONNECTION.

CONNECT USING ANNEALED COPPER PIPE OR A FLEXIBLE HOSE CAN BE USED PROVIDING THAT:

- Assembly acceptable by the local authority and complying with requirements of AS/NZS 1869, Class B and AS/NZS 5601
- Length of hose is kept to a minimum.
- The hose connection starts below the protective barrier (where required) installed 60 mm below the appliance.
- The hose is not subject to kinking abrasion or sharp edges.
- The supply connection point shall be accessible with the appliance installed.

NOTE: THE COOKER MUST BE INSTALLED WITH PROVISION TO ALLOW THE GAS TO BE TURNED OFF AND DISCONNECTED FOR SERVICING AND REMOVAL

1. For the LP Gas model the gas supply must be regulated to 2.75kPa; for Natural Gas regulated to 1kPa . A manual shut off valve must be installed in the gas supply line in an accessible position so that gas supply can be turned off in an emergency or for service. The cooktop data plate gives details of injector sizes and gas rates.
2. After installing the gas supply ensure that all gas controls are in the off position , then check all connections thoroughly for leaks
3. Plug the electrical connection in.
Turn each gas control on and adjust to obtain a clear blue flame with no yellow tipping. For adjustments refer to the attached servicing instructions. The first time you ignite the burners they may not ignite immediately. This is due to air in the gas lines that should clear within a few seconds. If satisfactory performance cannot be obtained contact the local gas authority for advice and assistance.
Fill in the warranty model details in this book taking information from the data plate where necessary.
Instruct the owner in safe operation of the appliance and ensure that these instructions are left with the appliance.

Before Leaving - Check all connections for gas leaks with soap and water. **DO NOT** use a naked flame for detecting leaks. Ignite all burners both individually and concurrently to ensure correct operation of gas valves, burners and ignition. Turn gas taps to low flame position and observe stability of the flame for each burner individually and concurrently. When satisfied with the hotplate, please instruct the user on the correct method of operation. In case the appliance fails to operate correctly after all checks have been carried out, refer to the authorised service provider in your area.

GAS CONNECTION

- Do not use as a room heater.
- Do not allow clothing to pass over or near to the flame.
- Do not leave handles of saucepans protruding out into the room or over adjacent burners. Always check that the pot is stable and will not be likely to tip its contents before you release your grip.
- Do not store items of interest to children in the cabinets above the appliance. Children climbing or standing on the appliance could result in serious injury.
- Do not position pans off centre to the burner. Adjust the flame to remain under the pan.

ABNORMAL OPERATION

If you are aware of any change in the operation of the appliance consult a qualified service person. This could be such things as noisy flame due to burner lit back or part being dislodged during cleaning. Do not use the appliance if the ceramic surface is accidentally damaged, contact your local service agent.

WARNING: IF THE CERAMIC IS CRACKED, SWITCH OFF TO AVOID THE POSSIBILITY OF ELECTRICAL SHOCK.

LEGEND AND MANUAL IGNITION FOR GAS BURNERS

SELECTED MODELS ONLY

LEGEND - GAS CONTROL GRAPHICS - Full Spectrum BURNER

MAX - Both inner and outer burners are operating at maximum output.

MED - The inner burner remains on full output, but the outer burner is on minimum output.

LOW - The inner burner is on full output and the outer burner is extinguished.

MID - The inner burner is on minimum output and the outer burner remains extinguished.

LEGEND - GAS CONTROL GRAPHICS - 'A' 'B' AND 'C' BURNERS

MAX - The burner is operating at maximum output.

MED - The inner burner remains on full output, but the outer burner is on minimum output.

SIMMER - The burner is operating at lowest output setting.

LEGEND - GAS CONTROL GRAPHICS - 'A' 'B' AND 'C' BURNERS

MAX - the burner is operating at maximum output.

MED - the burner is operating at medium output.

SIMMER - The burner is operating at lowest output setting.

MANUAL IGNITION GAS

If there is no power to the appliance or your area is experiencing a power black-out simply strike a match or spark igniter next to the required burner and follow steps in chapter 4 above

NOTE: THE FLAME FAILURE SYSTEM IS INDEPENDENT OF POWER AND WILL STILL OPERATE WITHOUT A

POWER SOURCE.

Should your cooktop fail to ignite after the manual procedure has been followed check to see that the gas supply to the appliance has not been turned off.

GENERAL ASSEMBLY PROCEDURE FOR INSTALLATION

PLEASE KEEP AND READ FOR FUTURE REFERENCE

GENERAL ASSEMBLY PROCEDURE FOR INSTALLATION

Ensure all packaging, including polystyrene, plastic and cardboard has been removed from around the appliance and burner area.

Ensure that all burner(s), trivets, grates and panels are correctly located and supported.

ABNORMAL OPERATION

If you are aware of any change in the operation of the appliance consult a qualified service person. This could be such things as: Noisy flame due to burner being lit back or parts being dislodged during cleaning. Do not use the appliance if the ceramic surface is accidentally damaged, contact your local service agent

WARNING: IF THE CERAMIC SURFACE IS CRACKED, SWITCH OFF TO AVOID THE POSSIBILITY OF ELECTRICAL SHOCK.

THE GAS OPERATION

Assembly of the FullSpectrum burner

1. Ensure that the locating pin `A` on the distributor ring is securely located in the recess hole of the FullSpectrum burner body. This is easily achieved by placing the distributor ring on the FullSpectrum body and then rotating the distributor until the locating bezzle `A` drops into the recess with a firm level fit being then accomplished.
2. The black dress ring should then be fitted over the top of the distributor ring.
3. The outer burner cap should then be placed onto the distributor ring with the locating pin `B` securely locating in the location recess `B` of the distributor ring. When correctly assembled the cross over on the outer cap should lie adjacent to the spark electrode protruding from the burner body.
4. Finally, gently place the inner burner cap into position in the centre of the FullSpectrum burner.

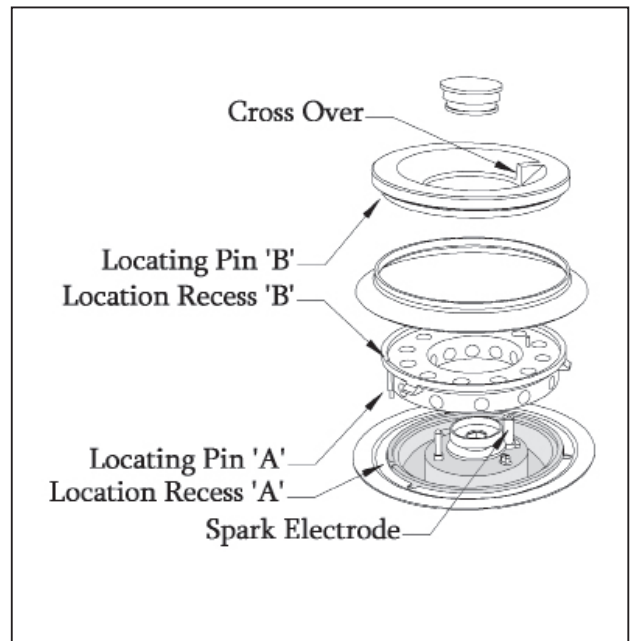

TO USE YOUR NEW FRANKE COOKTOP

PLEASE KEEP AND READ FOR FUTURE REFERENCE

1. Select the control knob corresponding to the burner you wish to use, press down and turn the knob to the position shown below.

NOTE: BURNERS WILL IMMEDIATELY BEGIN SPARKING VIA THE ELECTRONIC IGNITION SYSTEM WHEN ANY OF THE GAS CONTROLS ARE DEPRESSED. IF THERE IS NO IGNITION SPARK THEN THE APPLIANCE MAY NOT HAVE THE POWER TURNED ON. CHECK THE POWER POINT AND CONFIRM THE UNIT HAS POWER.

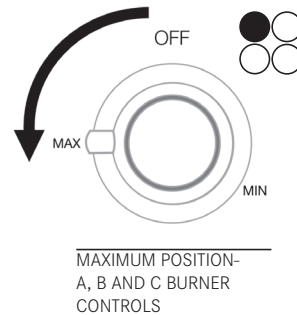
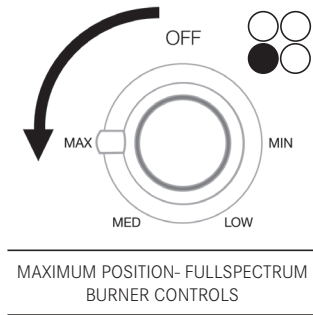

2. Press and hold the control knob down firmly for a full 5 seconds to ensure the flame failure device engages. If the flame goes out after you release the knob then the flame failure device did not engage – simply press down the knob firmly again turn to max position and keep pressing for a full 5 seconds.

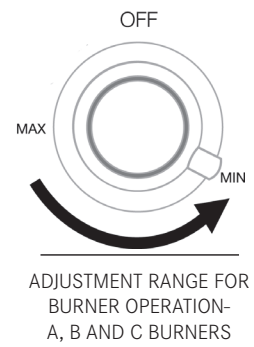
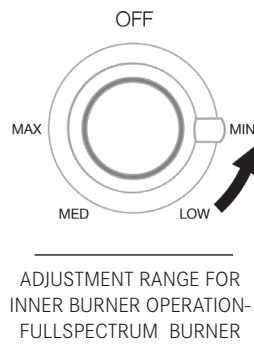
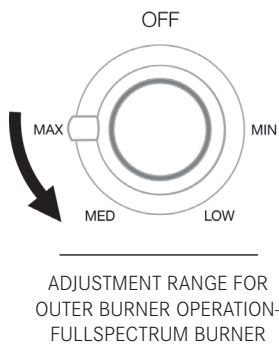

BURNER TOUCH CONTROL (FLG 1003B 1, FLG945B 1)

Set Time

- Press and hold [+] [-] buttons together.
- When the time begins to flash, release buttons.
- Press [+] button to go up.
- Press [-] button to go down.
- Press enter to set the minutes.
- Press enter to confirm time.

Set Timer

- Press enter. Time will flash.
- Enter the required minutes to the [+] [-] buttons and wait until a beep and the flashing stops.

Set Timer to Shut Off 1 Burner

- Press enter. Time will flash.
- Enter the required minutes with [+] [-] button and wait until a beep and flashing stops.
- To select burner, press enter after the time is set. Keep pressing enter until desired burner is selected. Wait for a beep and the timer to begin.
- Light burner when timer begins.
- If you want to add extra time before the timer ends, press enter and add more time.
- When the timer ends, a beep will begin.
- To stop beep, hold [-] button until another beep.
- To cancel timer, press and hold [-] until beep.

CARE & MAINTENANCE

SELECTED MODELS ONLY

CARE & MAINTENANCE :

1. Do not use excessively large vessels on your cooktop as damage and or hazard may occur.
2. Always remove food spills, dirt and grease spatters from your cooktop (see cleaning instructions)
Should you experience any problems with your appliance please call Franke Customer Care 1300511072

CLEANING GENERAL

1. **PAN SUPPORTS, TRIVETS:** These are made from cast iron and coated in a vitreous enamel to provide a resilient mat finish. These can be placed in the dishwasher (on a gentle cycle) or alternatively cleaned with a soft bristled brush in warm soapy water.
2. **BURNERS:** The burner caps are solid brass with a black chrome finish to avoid discoloration of the brass. NOTE: The black chrome will eventually burn off with time however this will not affect the performance of the burners. The burners can be re- chromed with Franke`s exchange program, for a nominal fee. The burner cap can be removed and cleaned with a soft bristled brush and warm soapy water or they can be placed in the dishwasher.

DO NOT use a steam cleaner to clean this appliance.

NOTE: AFTER CLEANING (ESPECIALLY IN A DISHWASHER) PLEASE ENSURE THAT THE PORTS (BURNER HOLES) ARE FREE OF ANY FOOD, WATER OR DEBRIS. THESE ARE EASILY CLEARED WITH A TOOTHPICK OR NEEDLE.

NOTE: DO NOT UNSCREW ANY PART OF THE BURNER SYSTEM.

3. **STAINLESS STEEL:** Should be cleaned with a commercially available stainless cleaner.

NOTE: DO NOT USE ABRASIVE POWDERS OR SCOURER PADS AS THESE WILL SCRATCH THE SURFACE OF THE STAINLESS STEEL.

NOTE: DO NOT USE AGGRESSIVE CHEMICAL CLEANERS LIKE AMMONIA OR OVEN CLEANERS AS THESE MAY ETCH OR DISCOLOUR THE SURFACE.

4. **CERAMIC GLASS:** After cooking it is recommended that the ceramic glass be cleaned with a commercially available glass cleaner (eg Windex) to remove any light spills or grease.

NOTE: STUBBORN STAINS AND BURNT FOOD SHOULD BE CLEANED WITH A CERAMIC GLASS CREAM AND REMOVED WITH A RAZOR SCRAPER. DO NOT USE SCOURING PADS OF ANY KIND. WE RECOMMEND APPLYING THE CREAM WITH A DRY CLOTH AND APPLYING IN A CIRCULAR RUBBING MOTION TO REMOVE THE STAIN/FOOD.

MAINTENANCE SCHEDULE

The appliance should be kept in a clean condition and you should ensure that removable parts are correctly reassembled. If the appliance has not been used for a long period of time check the appearance and the general performance of the burners. If the supply cord is damaged, it must be replaced by the manufacturer, its service agent or authorized person in order to avoid a hazard. In any event the appliance should be checked by a qualified person every five years and / or you should contact your dealer for any recommended maintenance.

FAULT FINDING / ABNORMAL OPERATION

FAULT FINDING / ABNORMAL OPERATION

| FAULT | POSSIBLE SOLUTION(S) |
|--|--|
| BURNER LIGHTS, BUT GOES OUT WHEN CONTROL IS RELEASED (GAS) | <p>CONTROL KNOB IS TO BE PRESSED DOWN FIRMLY, AND HELD FIRMLY, DURING IGNITION PROCEDURE FOR 5 SECONDS.</p> <p>CONTROL KNOB IS BOTTOMING OUT ON THE CONTROL PANEL AND NOT ENGAGING THE FLAME FAILURE DEVICE - HOLE IN KNOB NEEDS PACKING.</p> <p>IF THIS IS A FAULT PRESENT ON THE WOK BURNER, REFER TO THE CORRECT ASSEMBLY INSTRUCTIONS.</p> |
| UNIT OCCASIONALLY EMITS A SPARK EVEN WHEN NOT BEING OPERATED (GAS) | THIS USUALLY MEANS SOME MOISTURE ON THE SWITCHING MECHANISM DUE TO SPILLAGE OR STEAM. IT SHOULD SELF RECTIFY |
| FLAME ON WOK BURNER PRESENT UNDER SKIRT AND LARGE BILLOWING FLAME IN MIDDLE OF BURNER. (GAS) | FullSpectrum BURNER IS INCORRECTLY ASSEMBLED OR FOOD HAS BLOCKED PORTS. REFER TO ASSEMBLY INSTRUCTIONS. OR CLEAN. CONTINUED OPERATION IN THIS CONDITION MAY CAUSE DAMAGE. RECTIFY IMMEDIATELY |

TECHNICAL DATA

| Burner | Injector Size (LPG) | Injector Size (NG) | Nominal Gas Rate (LPG) | Nominal Gas Rate (NG) |
|------------|---------------------|--------------------|------------------------|-----------------------|
| Auxiliary | 0.72 mm | 1.15 mm | 6.5 MJ/h | 6.5 MJ/h |
| Semi Rapid | 0.80 mm | 1.35 mm | 8.5 MJ/h | 8.5 MJ/h |
| Rapid | 0.88 mm | 1.45 mm | 10.2 MJ/h | 10.2 MJ/h |
| Wok Inner | 0.46 mm | 0.63 mm | 2.3 MJ/h | 1.8 MJ/h |
| Wok Outer | 1.22 mm | 2.20 mm | 19.7 MJ/h | 20.2 MJ/h |

PR Kitchen & Washroom Systems Pty Ltd.
83 Bangholme Road
Dandenong South
VIC 3175
Australia
Phone +61 3 9700 9100
Fax +61 3 9700 9191
info@prks.com.au
www.franke.com.au

