



INSTRUCTIONS & INSTALLATION MANUAL

FCTSH90XB1

90CM T-SHAPE RANGEHOOD

EN USER MANUAL	3
INSTALLATION GUIDE	7

EN 1. SAFETY INFORMATION



For your safety and correct operation of the appliance, read this manual carefully before installation and use. Always keep these instructions with the appliance even if you move or sell it. Users must fully know the operation and safety features of the appliance.



The wire connection has to be done by qualified technician.

- The manufacturer will not be held liable for any damages resulting from incorrect or improper installation.
- The minimum safety distance between the cooker top and the extractor hood is 650 mm (some models can be installed at a lower height, please refer to the paragraphs on working dimensions and installation).
- If the instructions for installation for the gas hob specify a greater distance, this must be respected.
- Check that the mains voltage corresponds to that indicated on the rating plate fixed to the inside of the hood.
- Means for disconnection must be incorporated in the fixed wiring in accordance with the wiring rules.
- For Class I appliances, check that the domestic power supply guarantees adequate earthing.
- Connect the extractor to the exhaust flue through a pipe of minimum diameter 120 mm. The route of the flue must be as short as possible.
- Regulations concerning the discharge of air have to be fulfilled.
- Do not connect the extractor hood to exhaust ducts carrying combustion fumes (boilers, fire-places, etc.).
- If the extractor is used in conjunction with non-electrical appliances (e.g. gas burning appliances), a sufficient degree of aeration must be guaranteed in the room in order to prevent the backflow of exhaust gas. When the cooker hood is used in conjunction with appliances supplied with energy other than electric, the negative pressure in the room must not exceed 0,04 mbar to prevent fumes being drawn back into the room by the cooker hood.
- The air must not be discharged into a flue that is used for exhausting fumes from appliances burning gas or other fuels.
- If the supply cord is damaged, it must be replaced by the manufacturer or by its approved service agent.
- Connect the plug to a socket complying with current regulations, located in an accessible place.
- With regards to the technical and safety measures to be adopted for fume discharging

it is important to closely follow the regulations provided by the local authorities.

 **WARNING:** Before installing the Hood, remove the protective films.

- Use only screws and small parts in support of the hood.

 **WARNING:** Failure to install the screws or fixing device in accordance with these instructions may result in electrical hazards.

- Do not look directly at the light through optical devices (binoculars, magnifying glasses).
- Do not flambè under the range hood; risk of fire.
- This appliance is not intended for use by persons (including children) with reduced physical, sensory or mental capabilities or lack of experience and knowledge, unless they have been given supervision or instruction concerning use of the appliance by a person responsible for their safety.
- Children should be supervised to ensure that they do not play with the appliance.

 Accessible parts may become hot when used with cooking appliances.

- Clean and/or replace the Filters after the specified time period (Fire hazard). See paragraph Care and Cleaning.
- There is a fire risk if cleaning is not carried out in accordance with the instructions.
- There shall be adequate ventilation of the room when the range hood is used at the same time as appliances burning gas or other fuels (not applicable to appliances that only discharge the air back into the room).
- The symbol  on the product or on its packaging indicates that this product may not be treated as household waste. Instead it shall be handed over to the applicable collection point for the recycling of electrical and electronic equipment. By ensuring this product is disposed of correctly, you will help prevent potential negative consequences for the environment and human health, which could otherwise be caused by inappropriate waste handling of this product. For more detailed information about recycling of this product, please contact your local city office, your household waste disposal service or the shop where you purchased the product.

2. USE

- The extractor hood has been designed exclusively for domestic use to eliminate kitchen smells.
- Never use the hood for purposes other than for which it has been designed.
- Never leave high naked flames under the hood when it is in operation.
- Adjust the flame intensity to direct it onto the bottom of the pan only, making sure that it does not engulf the sides.
- Deep fat fryers must be continuously monitored during use: overheated oil can burst into flames.

3. CARE AND CLEANING

- The Activated charcoal filter is not washable and cannot be regenerated, and must be replaced approximately every 4 months of operation, or more frequently for particularly heavy usage (W).

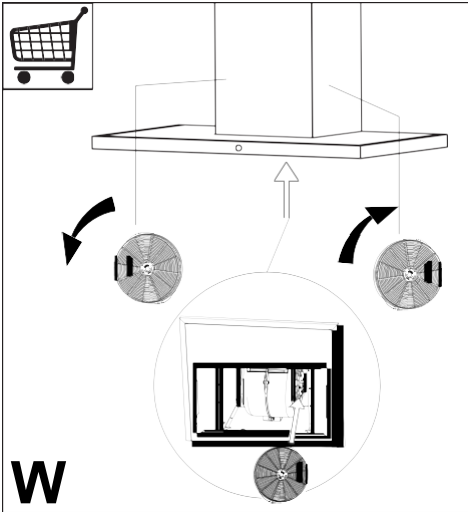

The Grease filters must be cleaned every 1 months of operation, or more frequently for particularly heavy usage, and can be washed in a dishwasher (Z).

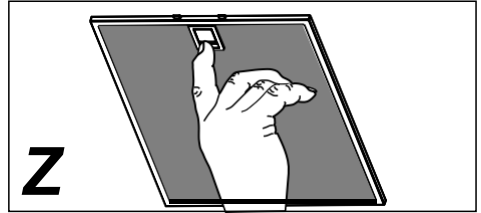

- Clean the hood using a damp cloth and a neutral liquid detergent.

4. CONTROLS

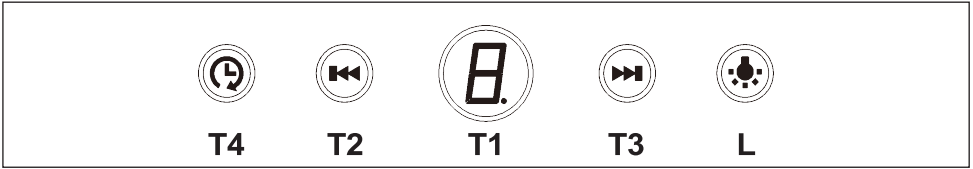

Button	Function	Led
T1	By pressing T1 Button the controls board are On and Off. After 2 minuts without button pressing, the control board turn Off.	Show 0
T2	Decreases the speed of the Motor.	Show the selected speed
T3	Increases the speed of the Motor.	Show the selected speed
T4	<p>1) Press briefly: Activates/Deactivates the Delay</p> <p>2) Press and hold for at least 3 seconds: Activates the Delay settings</p> <p>Enable shutdown with same minutes delay (Motor+Lights). It is possible to change the operating speed when this function is enabled.</p> <p>It's possible to choose the timing of Delay: Press for 3 seconds the button until the Digit flash. Within 10 seconds set from 1 to 9 the minutes of Delay by pressing T2 or T3 button. Press again the Button T4 to confirm.</p>	Flash
L	Turns the Lighting System on and off.	On / Off

5. LIGHTING

- For replacement contact technical support (“To purchase contact technical support”).

INSTALLATION MANUAL

Warning!

Before proceeding with installation, please read the recommendations and suggestions in the user manual.





I = 9x



L = 9x



P1 = 2x



N1

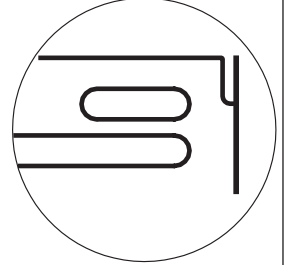
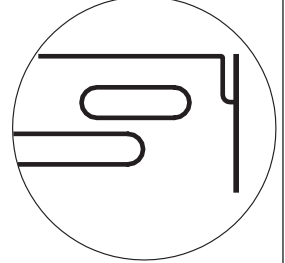
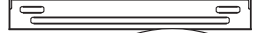
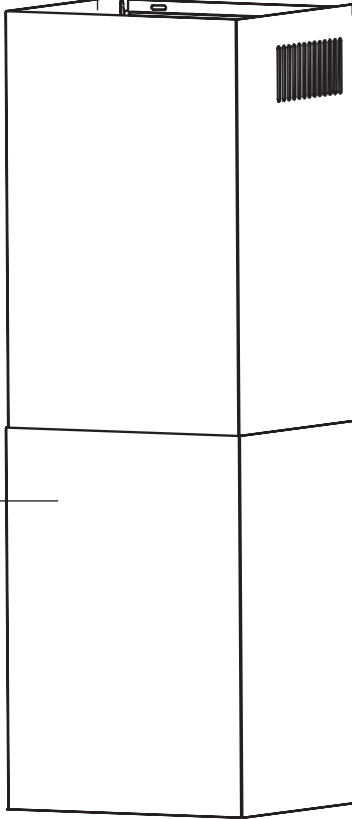

N2

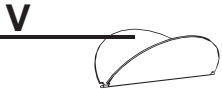

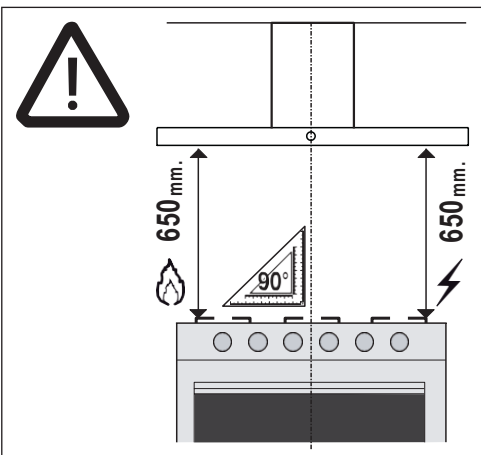
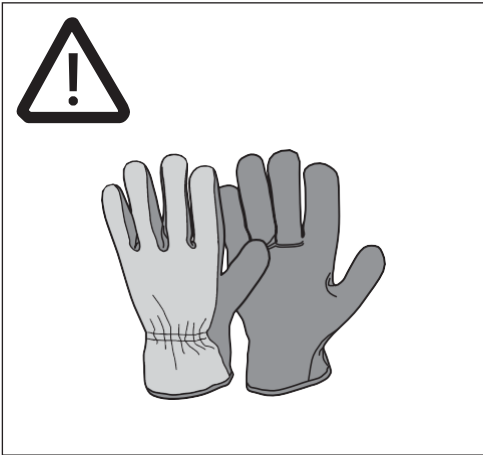
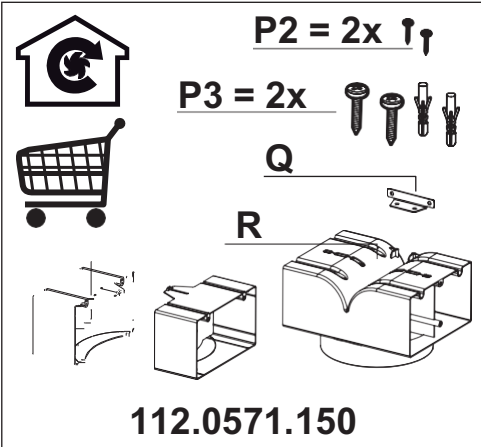
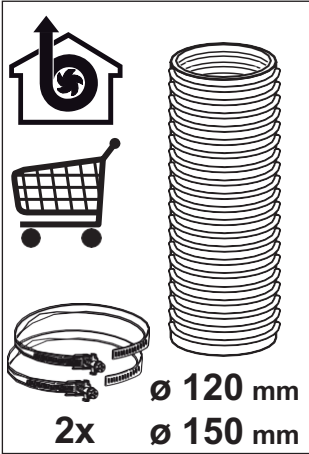

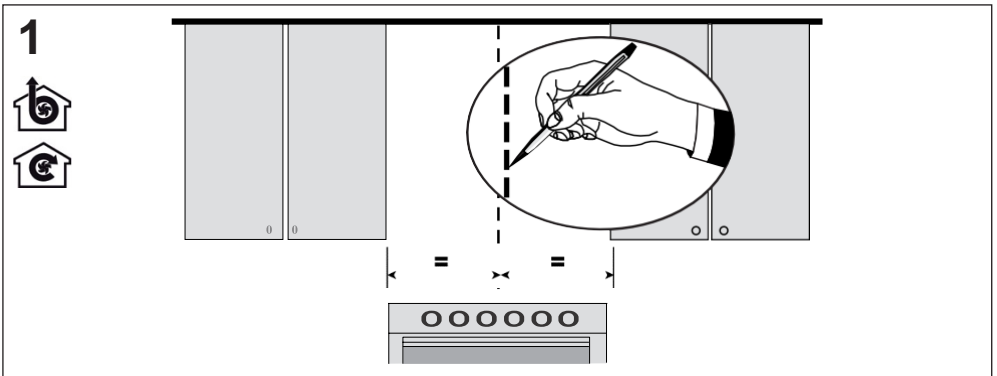
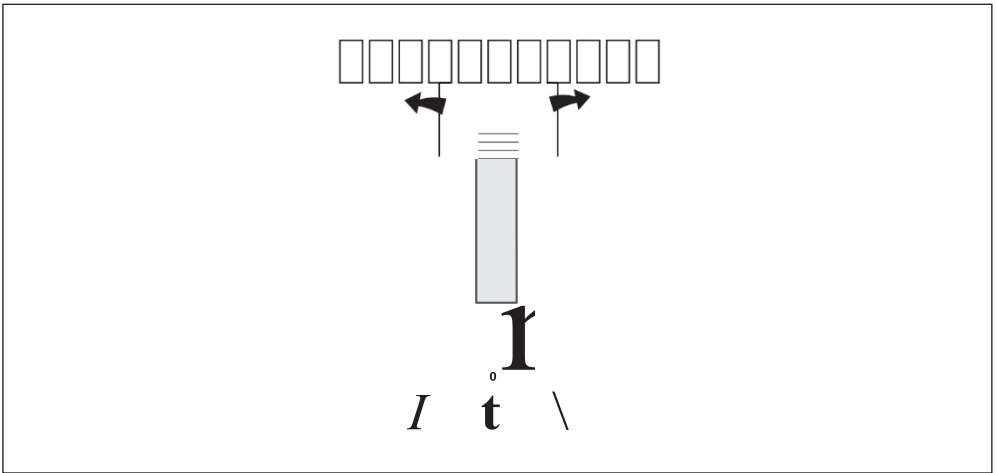
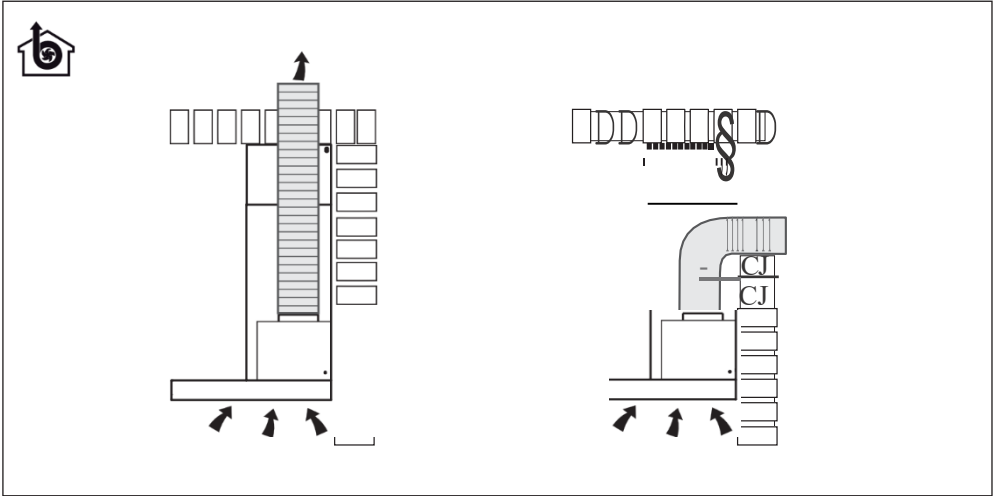

2

@

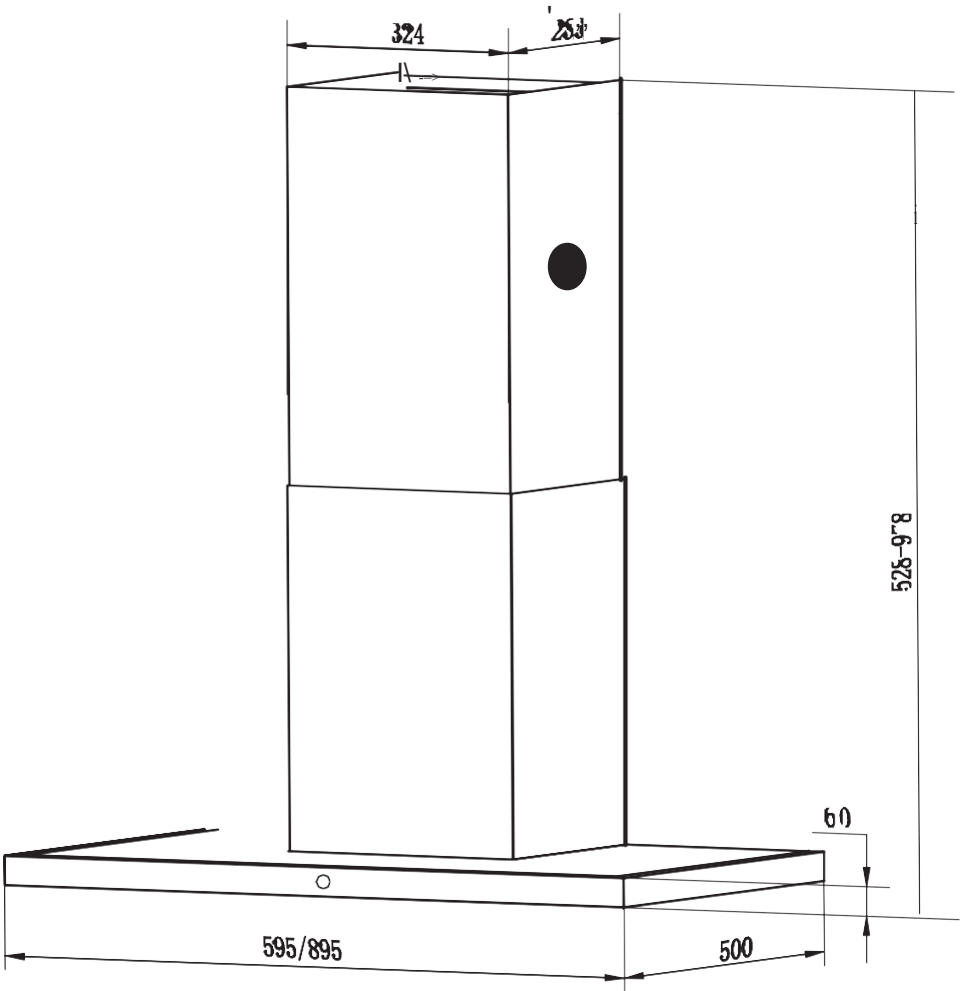

12 **WARNING:** Failure to install the screws or fixing device in accordance with these instructions may result in electrical hazards.:

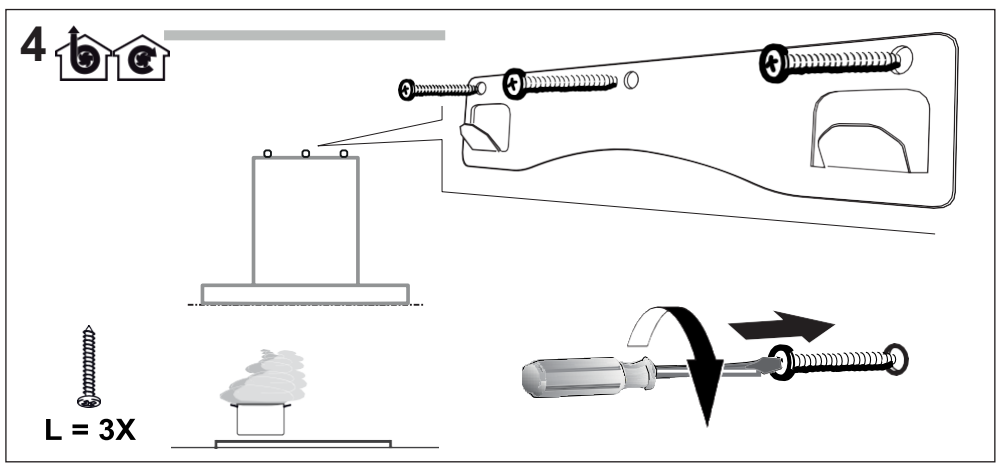
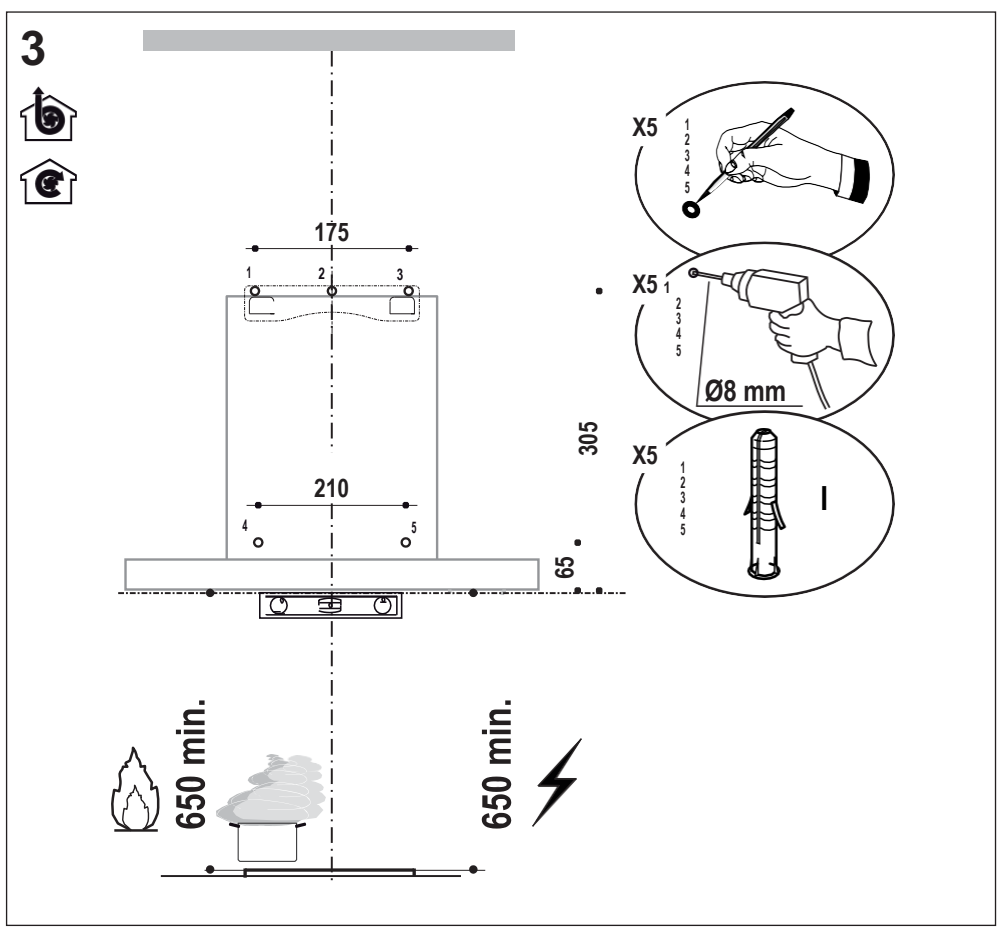

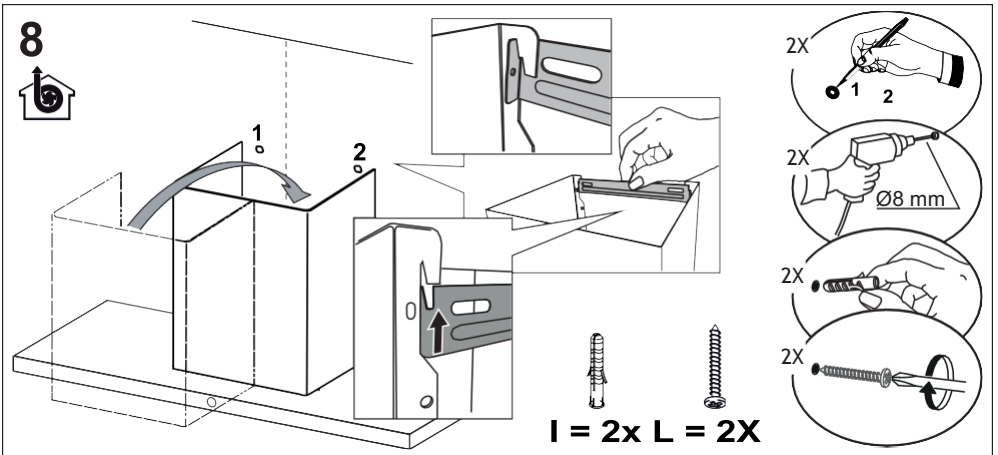
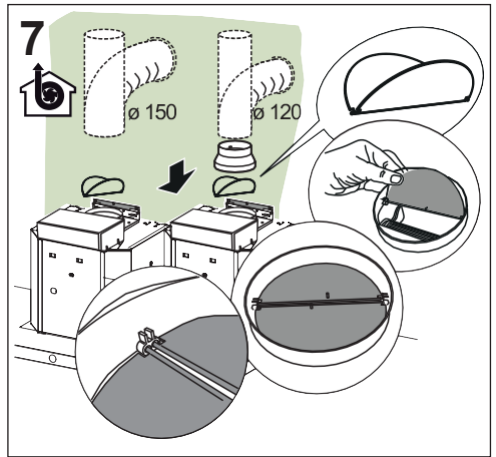
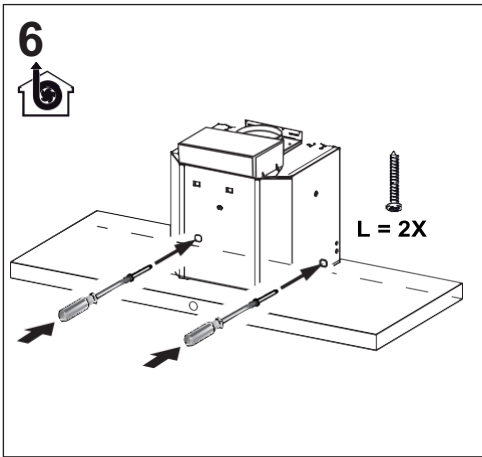
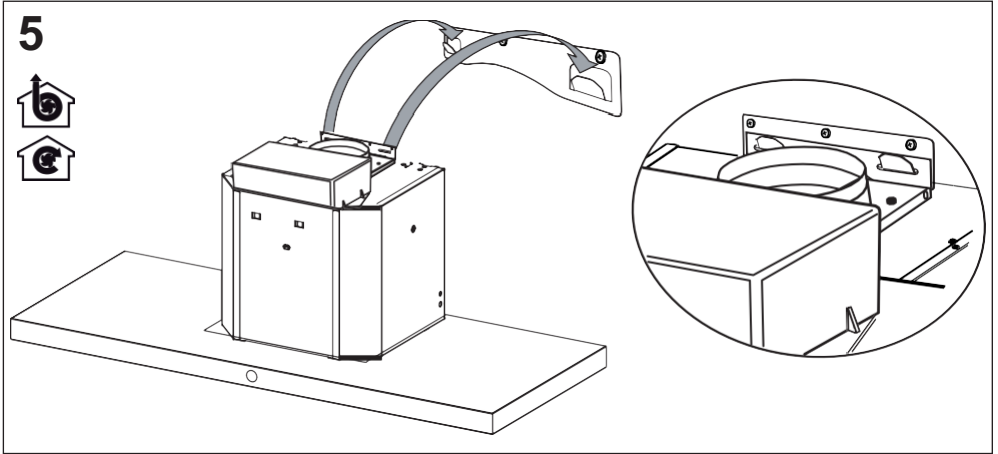

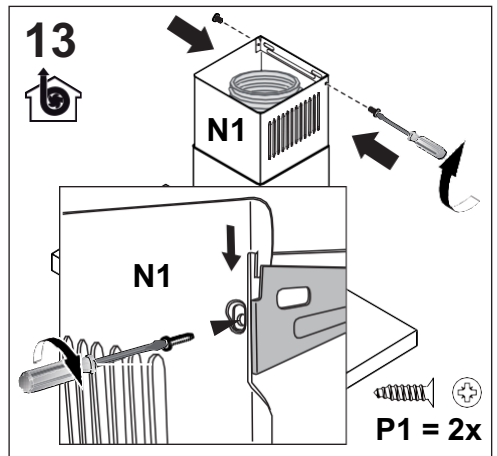
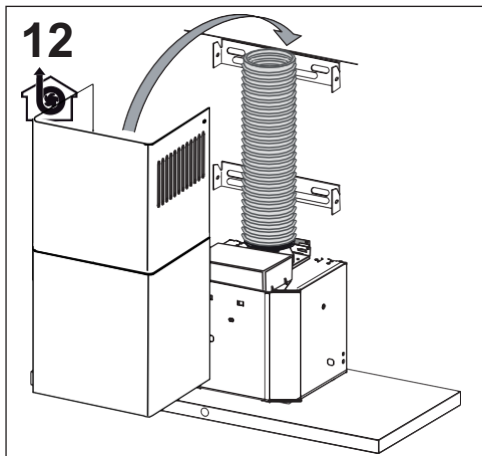
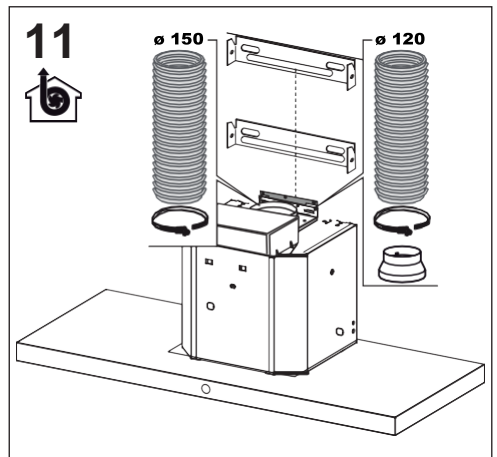
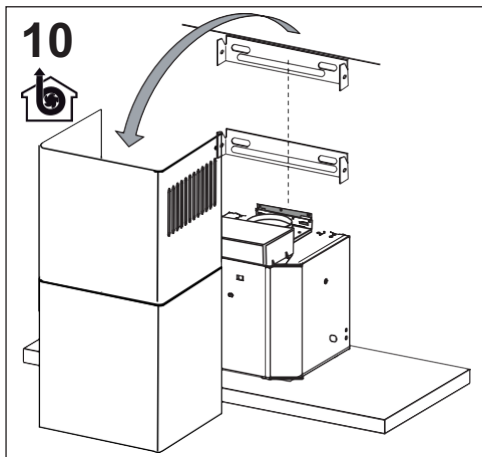
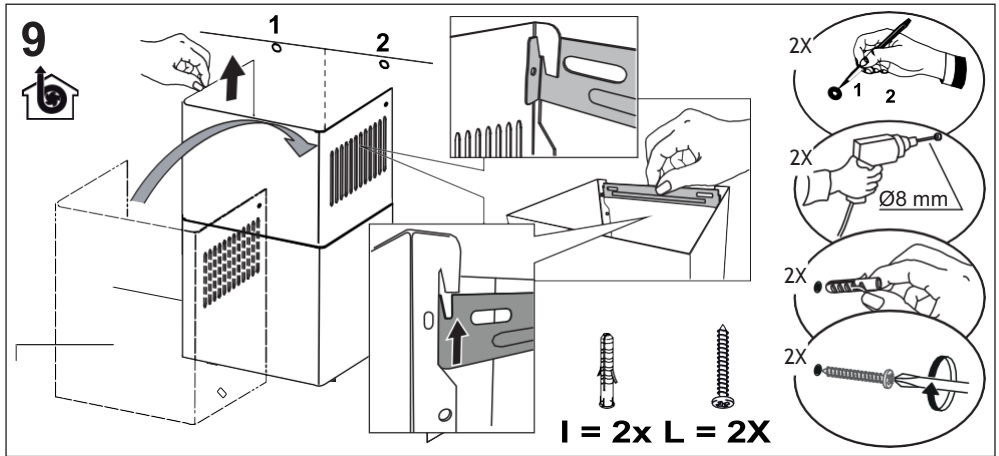

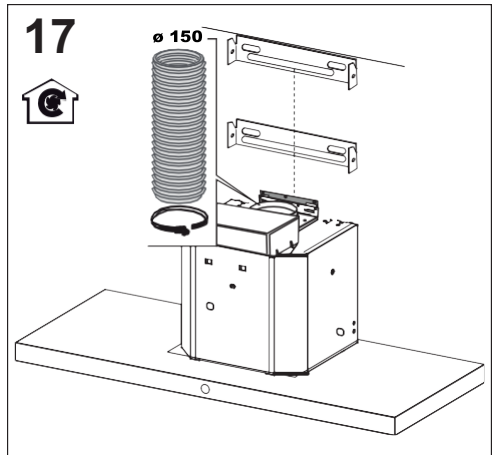
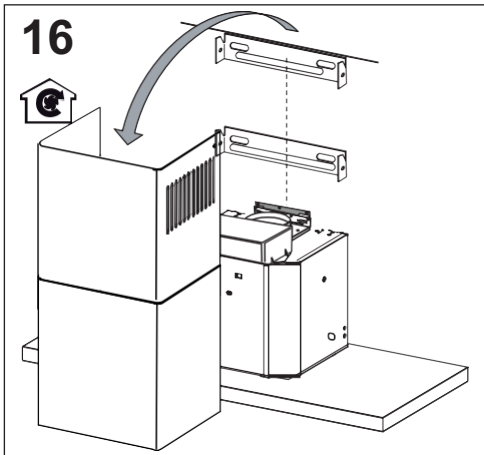
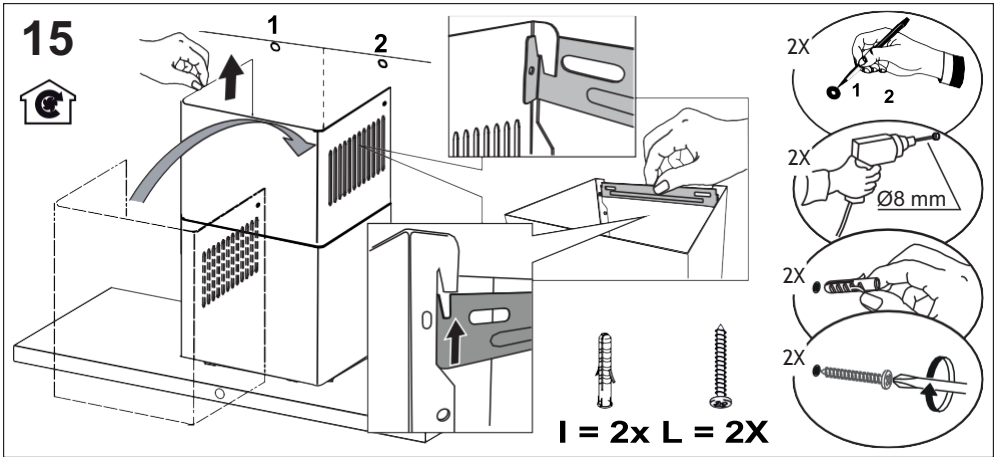
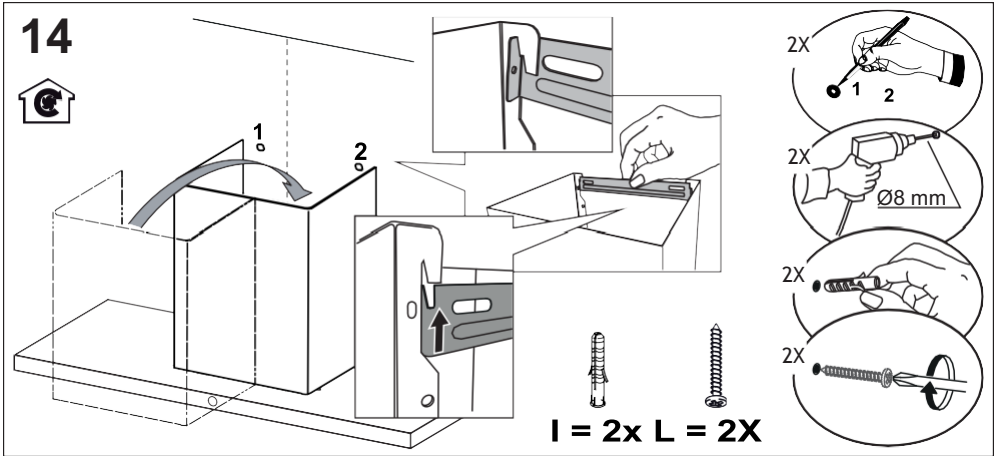

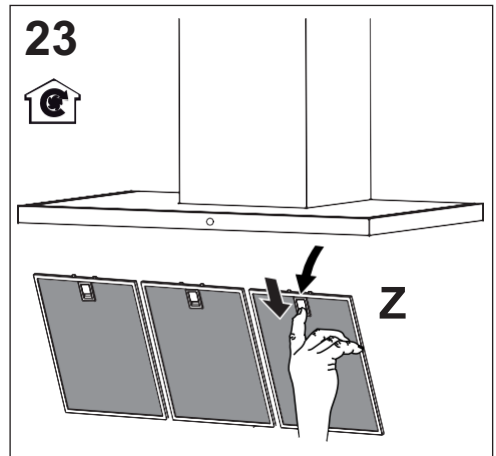
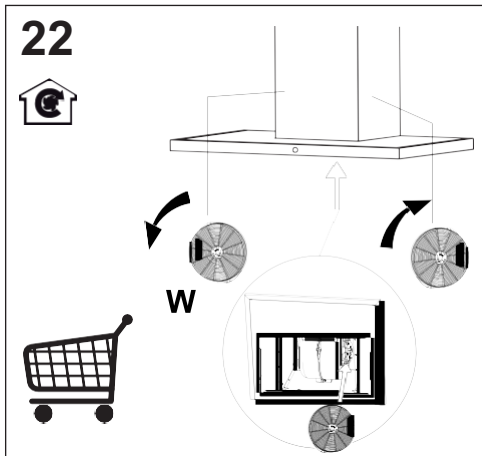
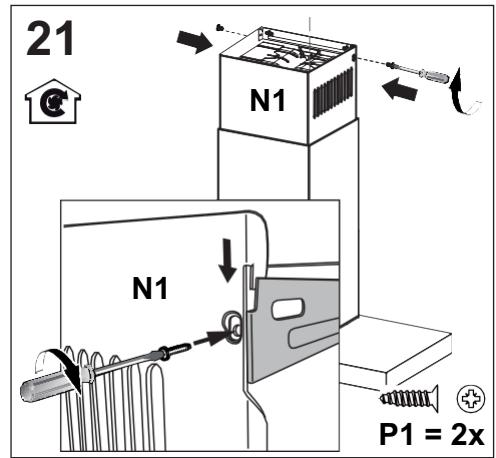
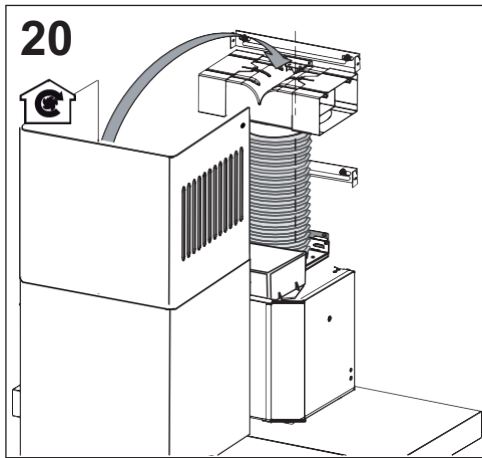
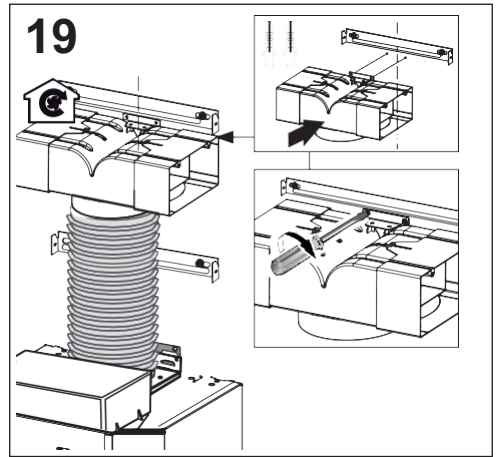
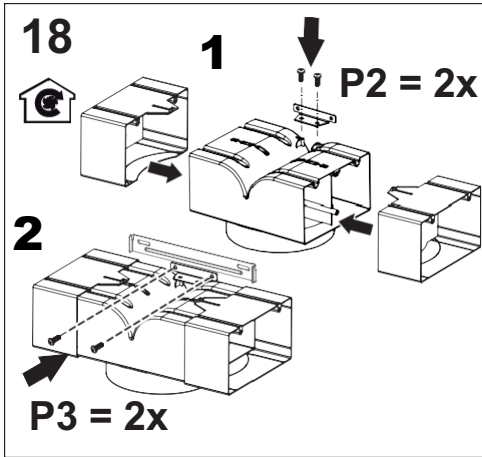

24

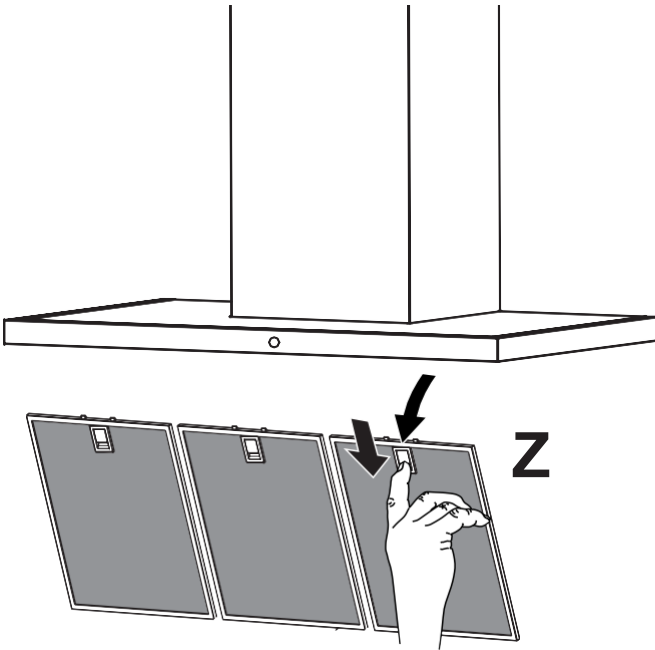
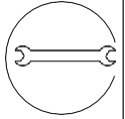

25

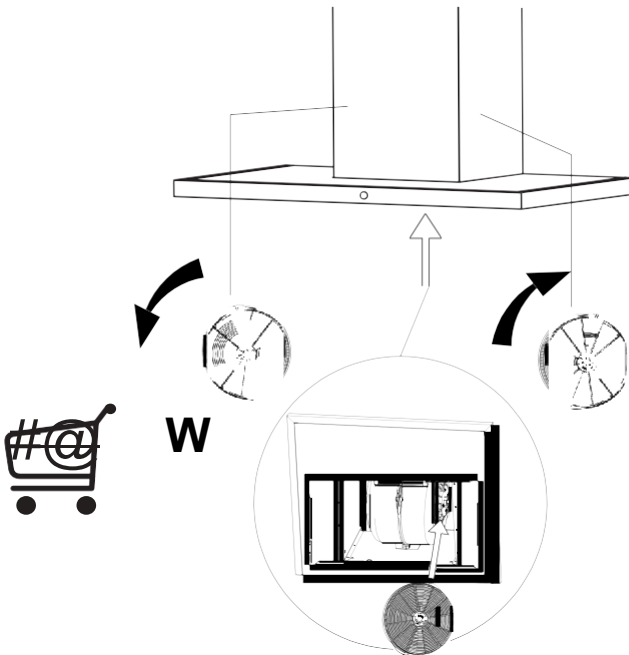
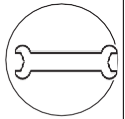

Franke – Urban Appliances Express Warranty

Australian Consumer Guarantees

Our goods come with guarantees that cannot be excluded under the Australian Consumer Law. You are entitled to a replacement or refund for a major failure and compensation for any other reasonably foreseeable loss or damage. You are also entitled to have the goods repaired or replaced if the goods fail to be of acceptable quality and the failure does not amount to a major failure.

Express Warranty Details

As well as your consumer guarantees under the Australian Consumer Law, PR Kitchen and Washroom Systems Pty Ltd ACN 138 663 279 (**PRKS**) offers original purchasers of the Products (**Customer** or **you**) the additional express warranty described in this document (**Express Warranty**) in respect of Urban appliances used in a domestic/residential setting (**Product**).

The benefits provided under this Express Warranty are additional to other rights and remedies available to the Customer under the Australian Consumer Law and do not derogate or reduce your rights under the Australian Consumer Law.

The conditions, limitations and exclusions that apply to this Express Warranty are set out in this document.

This Express Warranty is not transferable and is given to Customers when the Product is used in a domestic or residential setting.

Term of the Express Warranty

The Express Warranty is valid for 2 Years from date of purchase of the Product (**Warranty Period**).

Express Warranty

Subject to the terms set out in this document, PRKS warrants to Customers that the Product will be free from defects in materials and workmanship during the Warranty Period.

If the Product fails to operate or is defective during the Warranty Period under normal operating conditions as a result of a defect in materials or workmanship, subject to the exceptions set out under the heading **Conditions** below, PRKS will, at its discretion either:

- replace the Product or a component of the Product; or
- repair the Product or a component of the Product using new, used or refurbished replacement parts,

Conditions

This Express Warranty does not cover and expressly excludes damage to the Product or a defect in or failure of the Product resulting directly or indirectly from any of the following:

- alteration, modification, or disassembly of the product.
- the Product being used in a way for which it was not designed or in a manner contrary to the instructions provided with the Product (including in respect of maintenance of the Product).
- abuse, misuse, negligence, wilful damage neglect or vandalism.
- corrosion from environmental conditions or chemical treatments.
- fire, accident, or theft.
- damage caused while the Product is being
- external sources, including but not limited to blown fuses, power failure, faulty installation.
- natural disasters, or other 'acts of God', including but not limited to damage from flooding, drought, lightning, hurricanes, hail, windstorms, earthquakes, tornadoes, gales, cyclones, or other causes beyond the control of PRKS; or
- normal wear and tear
- scratching denting, rusting, spotting, discolouration or tampering with the Product. Any imperfections in the finishes or in the natural materials used should not be considered as faults but a typical characteristic of these crafted products.

- Products:
 - Used in commercial settings.
 - that were not installed in accordance with the manufacturer's installation instructions, by a qualified installer and licensed plumber or in accordance with any applicable standards published by Standards Australia that apply to the Product; or
 - that were purchased second hand, at auction, or from a person other than an authorised representative of PRKS;
- maintenance or repair performed by unauthorised persons and/or use of spare parts that are not genuine.
- when the Customer cannot provide documentation evidencing date of purchase of the product.
- incidental, indirect, or consequential loss or damage including loss of or damage to property, injury to, illness or death of, any person in connection with a Product failure or defect; or
- product removal or re-installation costs, visits and calls of specialised technicians and costs borne by the Customer due to the unavailability and/or non-use of the Product.

The Remedy is the sole remedy under this Express Warranty

Extra Representations

No representation or warranty by any person, including a PRKS employee or agent, shall be binding to the extent that they are inconsistent with or to the extent that the representation expands this Express Warranty unless expressly incorporated in writing in this document. This Express Warranty supersedes and overrides all prior agreements, representations and warranties made by PRKS and its authorised agents.

Making an Express Warranty Claim

If the Customer becomes aware, or ought to reasonably be aware of any defect, damage or deterioration to the Product, the Customer must stop using the Product and promptly report it to PRKS within the Warranty Period

To make a claim under this Express Warranty, please contact PRKS by submitting an enquiry at www.prks.com or you can call (03) 9700 9100 to speak with our friendly customer care consultants.

You will need to provide us with:

1. model number of your product
2. product identification
3. details of the problem you have experienced with the product.
4. a copy of your original purchase receipt.
5. address details of where the product is installed; and
6. any relevant pictures can be attached if lodging the claim online.

Expenses

Subject to the following terms, PRKS will provide the Remedy to the Customer at its cost:

- PRKS is not responsible for any associated or ancillary costs that you incur as a result of replacement or repair of your Product unless PRKS has given its prior written approval.
- Where a claim has been made under this Express Warranty and the Product is located outside of a 50km radius from any store where the Product can be purchased from an authorised retail (**Warranty Area**), you are responsible for the cost of delivery to the nearest service agent or the travel cost for a technician to travel to a location outside the Warranty Area.

PR Kitchen & Washroom Systems Pty Ltd

83 Bangholme Road
 Dandenong South, VIC 3175, Australia
 Phone: 03 9700 9100
 Email: customercare@prks.com.au
 Website: www.prks.com.au

CE

FRANKE