

TECHNICAL DATASHEET

FWD75 R

Product Category	Waste Disposers
Model	FWD75 R
Warranty	5 Years



PRODUCT INFORMATION

Overall Size	220 x 370mm
Air Switch	Cut-out size \varnothing 35mm
Motor Horsepower	3/4 hp
Motor Speed	2700 RPM
Key Features	<ul style="list-style-type: none">• Jam resistant technology• Space saving design• High speed Permanent Magnet Motor• Snap and lock universal mounting system• Energy efficient• 5 Year warranty
Additional Features	<ul style="list-style-type: none">• Integral air switch• Sound insulation

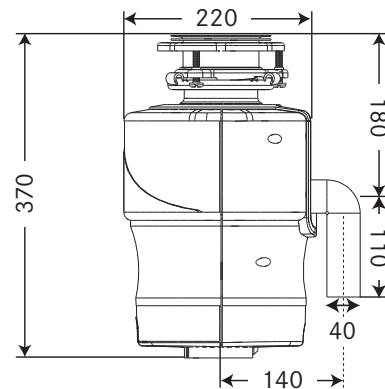

Make
it
Wonderful

FRANKE