

TECHNICAL DATASHEET

WD 50R

Product Category	Waste Disposers
Model	WD 50R
Warranty	5 Years



PRODUCT INFORMATION

Overall Size	220 x 370mm
Air Switch	N/A
Motor Horsepower	1/2 hp
Motor Speed	2600 RPM

Features

- Jam resistant technology
- Space saving design
- High speed Permanent Magnet Motor
- Snap and lock universal mounting system
- Energy efficient
- 5 Year warranty

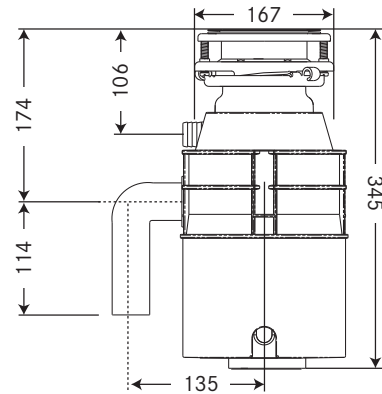

Make
it
Wonderful

FRANKE