

TECHNICAL DATASHEET

FLASH FLX 621 LHD

Product Category	Sinks
Finish	Stainless Steel
Installation	Topmount
Range	FLASH
Model	FLX 621 LHD
Warranty	50 Years



PRODUCT INFORMATION

Dimensions	1160 x 500mm
Cabinet Base	800mm
Bowl Size	340 x 420 x 160mm (x2)
Bowl Radius	80mm
Cut-Out Size	1140 x 480mm cr=10
Cut-Out Template	Yes
Waste Outlet	Semi Integrated Waste
Overflow	No
Tap Hole	Yes
Remote Waste	No
Accessories	1 2

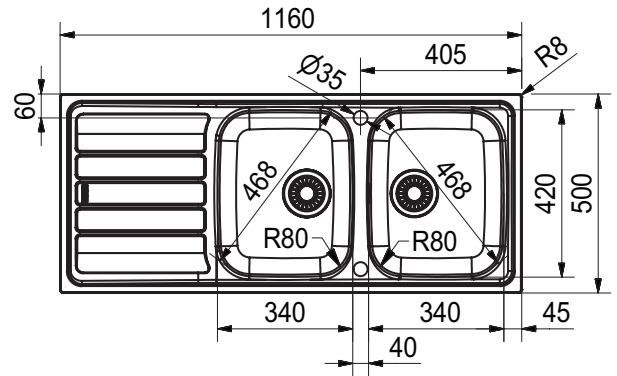

1 ACCESSORIES AVAILABLE **1** ACCESSORIES INCLUDED

ACCESSORIES

1



DB 664
Drainer Basket

2



CB 932
Chopping Board

FEATURES & BENEFITS



18/10
Stainless
Steel



Sound
Deadening
Pads