

TECHNICAL DATASHEET

FLASH FLX 621 RHD

| | |
|------------------|-----------------|
| Product Category | Sinks |
| Finish | Stainless Steel |
| Installation | Inset |
| Range | FLASH |
| Model | FLX 621 RHD |
| Warranty | 50 Years |



PRODUCT INFORMATION

| | |
|------------------|------------------------|
| Dimensions | 1160 x 500mm |
| Cabinet Base | 800mm |
| Bowl Size | 340 x 420 x 160mm (x2) |
| Bowl Radius | 15mm |
| Cut-Out Size | 1140 x 480mm cr=10 |
| Cut-Out Template | Yes |
| Waste Outlet | Semi Integrated Waste |
| Overflow | No |
| Tap Holes | Yes |
| Remote Waste | No |
| Accessories | 1 2 |

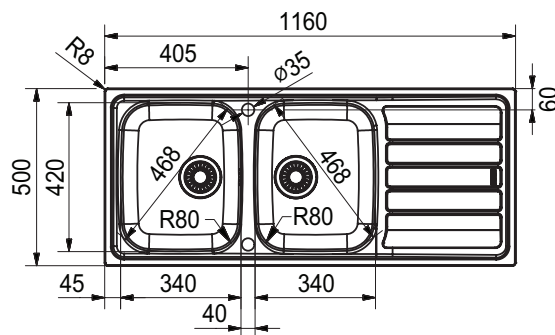

1 ACCESSORIES AVAILABLE **1** ACCESSORIES INCLUDED

ACCESSORIES

1



DB 664
Drainer Basket

2



CB 932
Chopping Board

FEATURES & BENEFITS



18/10
Stainless
Steel



Sound
Deadening
Pads

Make
it
Wonderful

FRANKE