



# A300 Fresh Brew



**Compact Consistency: Perfect Coffee, Every Cup.** The A300 Fresh Brew is our most compact coffee machine yet, powered by a 120V electrical connection for ultimate adaptability to any space – providing great coffee anywhere. This versatile machine serves both hot and iced coffee, offering two bean types, ground fresh on demand, along with two programmed water options for tea and hot water. Ideal for non-commercial spaces such as offices and hotels with limited space and staff but high demand for quality coffee. The A300 Fresh Brew is easy to operate for staff and customers alike, with features like the automated cleaning system, intuitive menu, and flexible configuration (plumbed or water reservoir).

**Because space should never get in the way of great coffee.**



### EasyClean

Automatic cleaning system — perfect hygiene in just a few steps



### Touch Screen

Easy to use and follow, even for new users



**Franke Digital Services**  
A clear view of commercial and operational performance.

# Technical Data

## A300 Fresh Brew Models

<b>Power</b>	110-127V 1LNPE 60Hz 1.2-1.5 kW (15A)
<b>Dimensions</b> - Plumbed with:	<b>Standard</b> (1.2 lb) hoppers with plumbed drip tray 10.6"W x 21.5"H x 23.1"D
<b>Dimensions</b> - Plumbed with:	<b>Optional</b> (0.55 lb) low-profile hoppers with plumbed drip tray 10.6"W x 18.3"H x 23.1"D
<b>Dimensions</b> - Water Reservoir with:	<b>Standard</b> (1.2 lb) hoppers with removable drip tray 13.4"W x 21.5"H x 23.1"D
<b>Dimensions</b> - Water Reservoir with:	<b>Optional</b> (0.55 lb) low-profile hoppers with removable drip tray 13.4"W x 18.3"H x 23.1"D
<b>Weight</b> (empty)	Approx. 55 lbs

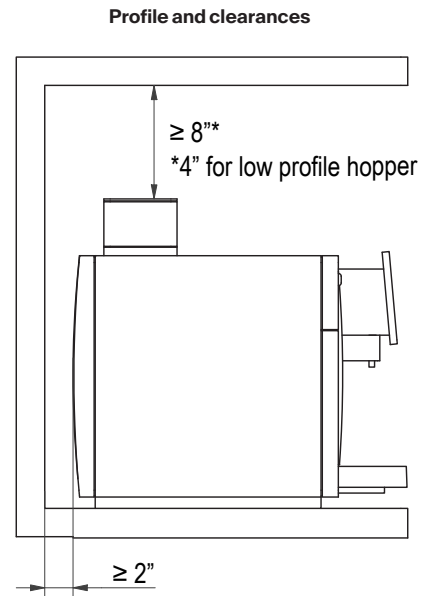
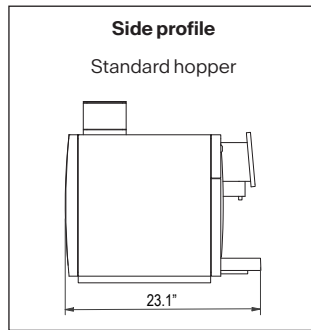
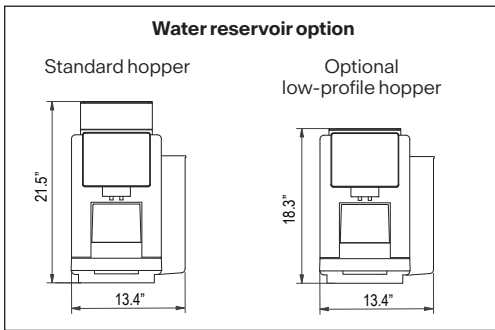
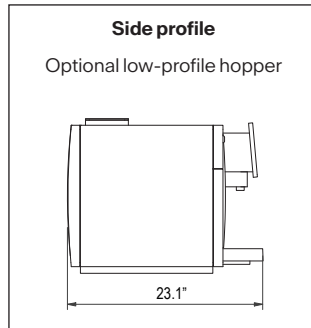
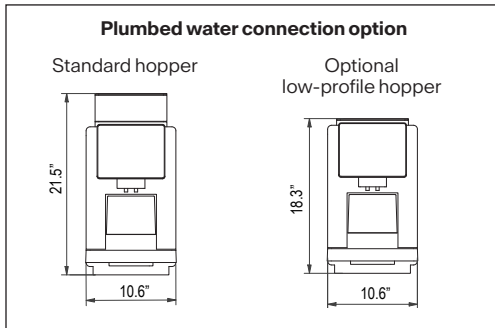

**Utility and grounds chute openings for optional plumbed water connection**

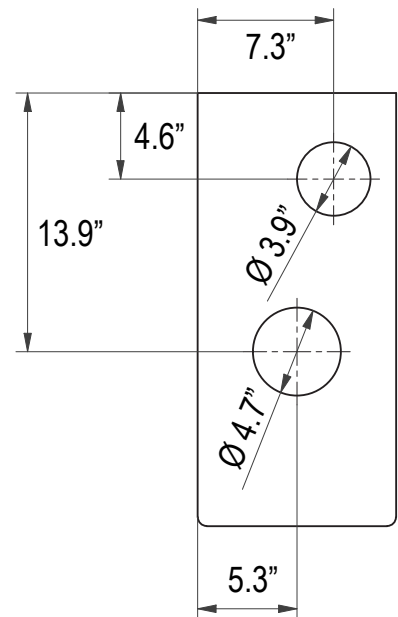

## Water quality requirements

Aroma	Fresh and pure taste, with no perceptible aroma
Color	Clear
Total Hardness	70 – 140 ppm (mg/l)
Carbonate hardness	3 – 6° dH CH (carbonate hardness) 50 – 105 ppm (mg/l)
Acid content/ph value	6.5 – 7.5 pH
Chlorine content	< 0.5 mg/l
Chloride content	< 30 mg/l
TDS (Total dissolved solids)	30 – 150 ppm (mg/l)
Electrical conductivity	50 – 200 µS/cm (microsiemens)
Iron Content	< 0.3 mg/l
Water pressure	80 – 800 kPa (0.8 – 8 bar)
Flow rate	> 0.1 l/sec
Water temperature	< 25°C

## Water connection and drain

Water connection	3/8" compression fitting, L = 59"
Drain hose	Dia = 0.75" OD, L - 78.7"



ETL LISTED CONFORMS TO  
UL STD 197 CERTIFIED TO  
CSA STD C22.2  
NO 1093 | 123505



CONFORMS TO  
NSF STD 4



**Franke Kaffeemaschinen AG**

cs-info.ch@franke.com

**Franke Coffee Systems GmbH**

cs-info.de@franke.com

**Franke Coffee Systems Americas**

cs-coffeesales.us@franke.com

**Franke Coffee Systems UK**

sales@frankecoffeesystems.co.uk

us.coffee.franke.com